

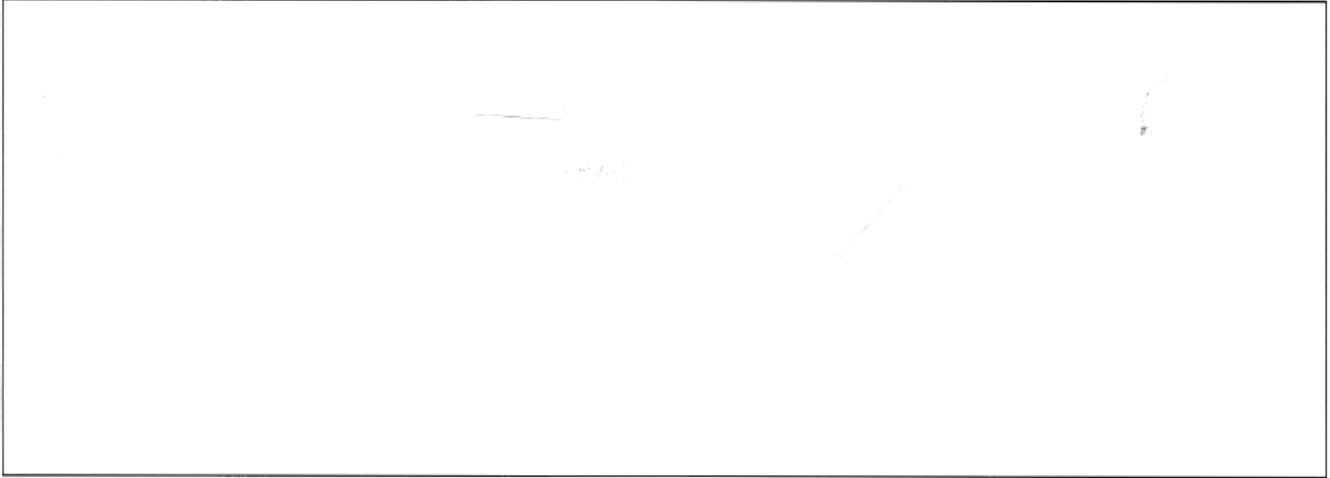

INSTRUCTION MANUAL  
**SHM**  
Sample Hold Module

Form 189-702-01A

January 1982



## GENERAL INFORMATION

### 1.1 SCOPE OF MANUAL

This manual contains operating and maintenance information on the Sample and Hold Module (SHM), manufactured by MOORE INDUSTRIES INC., Sepulveda, California. The manual consists of six sections, as follows:

Section 1, General Information, introduces the equipment function and describes the equipment physical appearance, the equipment specifications, and options available for the unit. The introduction also provides information on the use and description of the MOORE model numbering system.

Section 2, Calibration, provides all the information necessary to calibrate the unit before installation. This section contains a list of the tools necessary for calibrating the equipment; and illustrates the test setups essential to perform that task. The section also lists the various procedures required for calibration of the units in any configuration.

Section 3, Installation and Operation, supplies all the information needed to install and operate the equipment. The section contains figures that specify the installation requirements for the units, and text that informs the user on recommended wiring practices for the equipment as well as defines the electrical connections for each unit regardless of physical modifications. A brief outline of periodic observations required during the equipment operation is also included here.

Section 4, Theory of Operation, gives the maintenance personnel a detailed explanation of the internal function of the unit. The circuit theory is based on a block diagram that shows the functional elements of the unit. Each element operation is then described, first in relation to the other element, then independently where its major components' use and purpose are described.

Section 5, Maintenance, offers complete disassembly procedures for all unit configurations available. Troubleshooting information is also provided in this section as well as component replacement techniques to aid the technician in the repair of the equipment.

Section 6, Unit Documentation, acquaints the user with the MOORE IND. computerized parts listing and identification system. The section also provides a recommended spare parts list. All schematics and parts assembly drawings referred to by the text are located in the back of Section 6.

### 1.2 EQUIPMENT DESCRIPTION

Upon receipt of a sample command pulse, the Sample and Hold Module (SHM) samples an incoming signal and the output reaches a corresponding level within 0.1 second. The output remains at the sampled level until a new command pulse is received. The SHM is applicable to telemetering systems where data is being transmitted in time-multiplexed pulse-duration or amplitude form. It may also be used in chromatograph systems to store the output representing the quantity of a selected substance. In this application, the sample command may be a momentary contact closure (customer-furnished) across the command-signal input terminals.

An external processing input signal between +IN and -IN is applied to a differential amplifier that supplies a fold-over prevention circuit for the A to D counters. The output of this element is sampled by a comparator circuit. If the control signal at the HC terminals is not present, no sampling occurs. A control signal at HC initiates a sampling of the input signal for 100 milliseconds. At the end of that period, the sampling circuit resumes its hold condition, no sampling occurs, and the output of the sampling circuit remains at the level it reached just before the sampling mode was interrupted. The output of the sampling circuit is divided down by a voltage divider. Portions of that signal are picked-off by the SPAN control and amplified to produce the desired output level.

Alternative sampling options are available: a track and hold (TR) mode and a peakpicker (PP) mode. The TR option allows the state of the control signal to directly control the mode of the sampling circuit. In the peakpicker option, sampling occurs when a peak signal is present on the external input lines. In this option the control input is used as a reset command to force sampling during times other than peak periods. Refer to Table 1-3 for a complete list of available SHM electrical options.

### 1.3 PHYSICAL DESCRIPTION

The SHM is available in several different physical configurations. In general, the unit consists of a main circuit board and two small boards mounted on the main board. One small board PC2 contains an A to D converter. The other small board contains the digital sampling control circuits. These circuits vary according to the option included in the unit. This board is labeled PC3 for the standard sampling mode, PC4 for the tracking option and PC5 for the peakpicker option. The main board PC1 contains the remaining analog circuits.

The boards are enclosed in a protective housing, and the entire assembly may be installed in a number of ways. Specific details about each unit is outlined in this section, while the following paragraphs outline the physical differences of each option available for the units. Electrical connections information are given in Section 3, Installation and Operation.



Standard (SD) Unit

#### 1.3.1 Conduit Plate Option (CP) Description

This option consists of an extension of the standard bracket lower mounting flange. The additional surface is cut with two mounting holes to accommodate 1/2-inch electrical conduit. This option is illustrated in Section 3 outline and dimension drawings.

#### 1.3.2 Angle Bracket (AB) Option Description

This option consists of two angle brackets, one on the top and the other on the bottom of the unit.

These brackets are used to mount the unit in applications where the standard U-bracket will not apply. The brackets are provided with two #10 screw clearance holes each, for ease of mounting.



Unit with Angle Bracket (AB) Option

#### 1.3.3 NEMA Boxes Options Description

Units equipped with angle brackets (AB) option may be enclosed in NEMA boxes to ensure protection against harsh environments that may be damaging to the unit. Four configurations are available for this purpose.

**Oil Tight (OT) NEMA Box Option.** This enclosure consists of a NEMA12 box construction, with two cover-holding screw clamps, mounted opposite to the hinged side of the cover (right side). These enclosures are oil and dust tight only. Conduit holes, fittings, or knockouts are not provided on these boxes. Suggested fittings are "Myer's Scrutite." The units are mounted on a drilled and tapped mounting plate at the back of the box.

**Water Tight (WT) NEMA Box Option.** This enclosure consists of a NEMA4 box construction equipped with three cover-holding screw clamps, one on each of the three non-hinged sides of the box. These enclosures are watertight, in addition to oil and dust tight. Unit mounting and electrical connections are made in the same manner as the OT option enclosures.

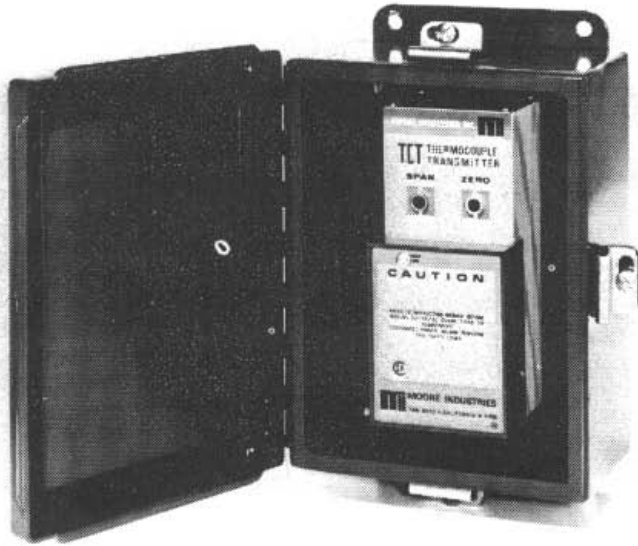

**Unit in Water Tight (WT) Enclosure**

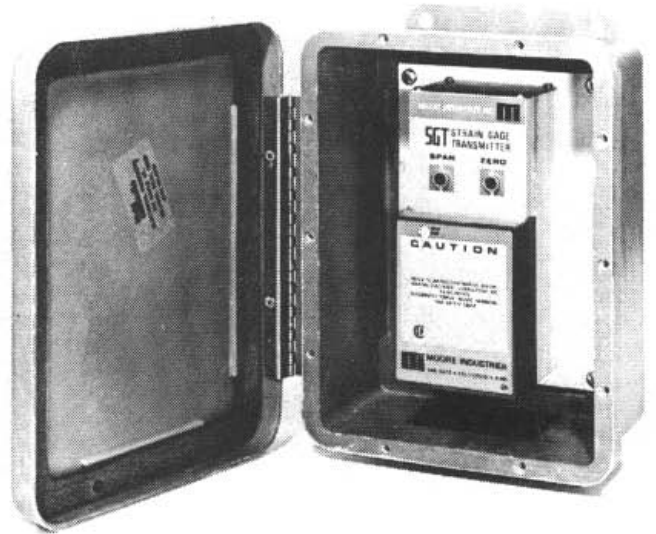

**Corrosion Resistant Fiber Glass (FG) Enclosure**

*Fiber Glass (FG) Option Enclosures.* This enclosure is molded from pigmented polyester resins, using 302 stainless steel for all exposed hardware. A one-piece neoprene jacket provides additional sealing protection against corrosive environments. Boxes are normally hinged on the long side. The cover is secured by four slot-head screws accessible at the top of the cover and located on each side of the top and bottom cover corners opposite the hinge side. Conduit holes may be cut with a hole punch, and special precautions must be taken with ground connections, since the box material is non-conductive. Refer to Section 3 for wiring information. Units are mounted into the enclosure in the same way as in the OT enclosures.

*General Purpose (GP) Options Enclosures.* This enclosure consists of a general purpose steel construction box with knock-outs for various size electrical conduits (1/2, 3/4, or 1 inch). The cover is hinged and spring locked. Units are secured into the enclosure on four studs and four 10-32 nuts. The complete enclosure can be secured through four mounting holes provided on the box back cover.

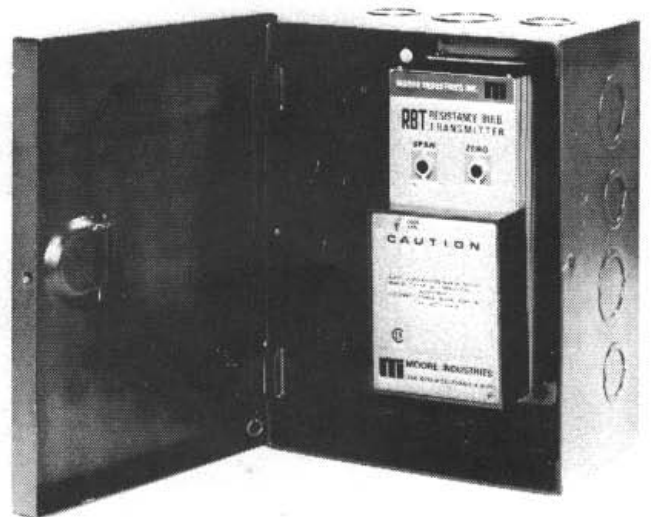

**General Purpose (GP) Enclosure**

### 1.3.4 AA and TA Options Description

These options consist of special mounting hardware attached to MOORE units to replace obsolete instrumentation of other manufacture.



Replacement Mounting (AA Option)

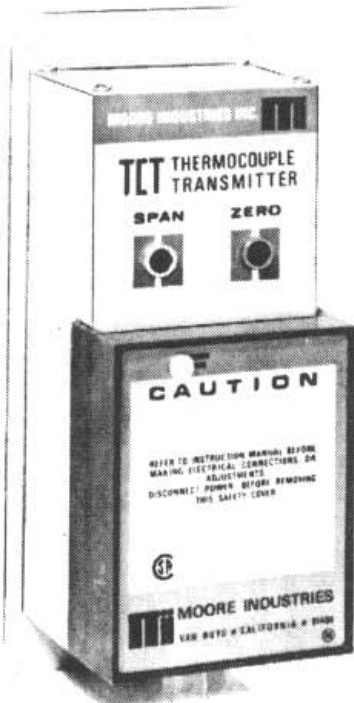

Replacement Mounting (TA Option)

### 1.3.5 Plug-In (PC) Units Description

The plug-in unit is electrically similar to the standard unit except that the unit consists of a main board and three small boards mounted on the main board PC1. One small board PC3 contains an A to D converter. Another small board contains the digital sampling control circuits. These circuits vary according to the option included in the unit. This board is labeled PC4 for standard sampling mode, PC5 for the tracking option and PC6 for the peakpicker option. The last small board mounted on the main board is PC2. This board contains all the output circuits used by the unit including the various current or voltage output option circuits. The printed circuit board is keyed to identify the unit and ensure proper connection mating. The other end of the main board is fastened to a display panel that allows external access to the various controls for the unit. A removable plastic safety cover protects the printed circuit board and components from normal environmental hazards. When the PC unit is purchased alone, the user must provide a 15 pin connector, such as Viking part No. ZVK155/1-2 or equivalent. Several mounting options are available for the plug-in unit.

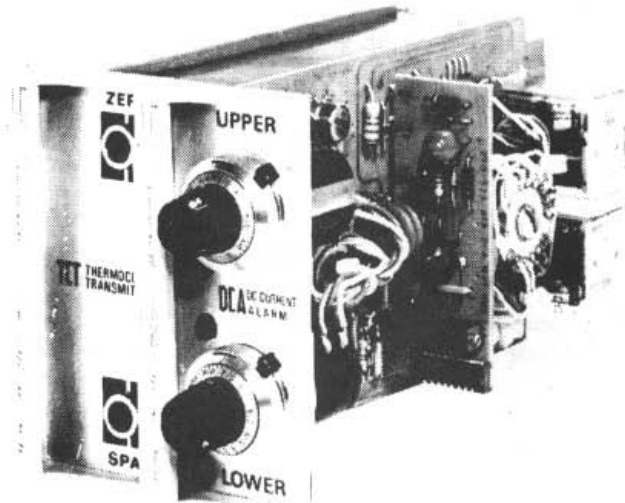

Plug-In (PC) Unit

*Rack Mounted (RMR) Card Racks.* These enclosures are designed to flush-mount in standard 19 and 24-inch relay racks, respectively. The enclosures are provided with standard EIA hole patterns. Eleven and fifteen position RMR racks are available. These are pre-wired from the module PC connector to the screw-type barrier strip, which are rear-accessed for rack-wiring convenience. All power connections from the PC connectors are bussed together to a separate 3 terminal barrier-strip for external power input. DC power supplies are available. Electrical connections to the card rack are detailed in Section 3, Installation and Operation. Modules are front loaded and a dust cover is provided to minimize the

effects of environmental hazards. Module connectors are keyed to assure that units are plugged into their proper position; keying, however, may be altered in the field if the system configuration changes. Filler cards are available for positions not used by a module.

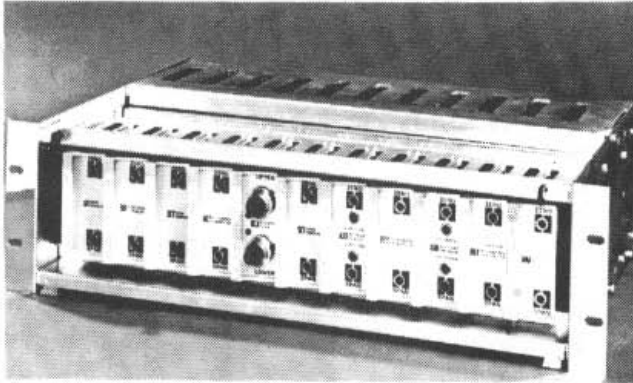

**Card Rack Enclosure for Relay Racks (RMR)**

*Surface Mounted (SMR) Card Rack.* These rack enclosures are designed to accommodate as few as five and up to 15 modules. Mounting flanges are located in the rear of the side panel which allows for surface mounting or for NEMA box mounting. These enclosures are electrically identical in construction to the RMR racks. Terminal strips for external connections, however, are front-accessed for wiring convenience whenever the rack is mounted into a NEMA box or against a wall.

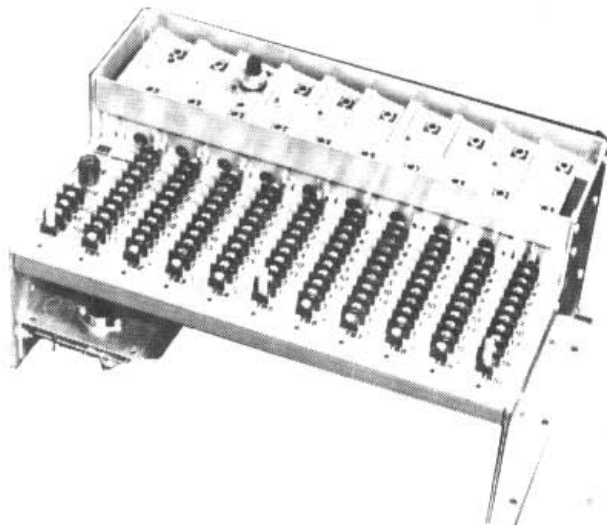

**Surface Mounted Card Racks (SMR)**

### 1.3.6 Standard Plug-In Transmitter (PB and PT) Options

The standard plug-in transmitter consists of a standard enclosure as described in paragraph 1.3 except that connections are not provided on the face of the unit. Instead, the transmitter is attached physically and electrically to a circular interconnect card with plug-in pins, keyed to eliminate errors in connections. The mating connector consists of a bracket-mounted square terminal block. External electrical connections are made to screw terminals located on the periphery of the connector block. A plug-in receptacle arrangement is located in the center of the block to accommodate the keyed interconnect card plug-in pins from the transmitter. The mounting bracket secured to the terminal block is pre-drilled with clearance holes for 10-32 screws. When the transmitter assembly is removed, the terminal block screw connections are easily accessible.

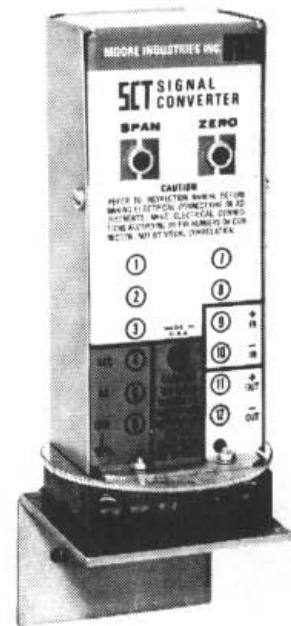

**Plug-In Standard Unit (PB)**

### 3 Explosion Proof (CT, XT) Option

The explosion-proof enclosure option consists of a PT option unit described in paragraph 1.3.6 enclosed into a two-piece cast aluminum alloy enclosure. The two pieces consist of a screw-type

cover and a connector housing. When the cover is removed, the PB type unit is easily accessible. With the PB unit unplugged, the terminal block is clearly visible and connections are made with ease. No mounting bracket is used on the terminal block as with the PB option. Instead, the terminal block is secured flush with the bottom of the housing. Electrical conduit hubs are provided for external electrical wiring through electrical conduits. Several configurations of conduit inputs are available. Refer to Section 3 for detailed description of conduit configurations.



Explosion Proof Housing (CT Shown Only)

### 1.3.8 Panel Mounted Transmitter (PM) Option

This option is electrically similar to the standard unit of paragraph 1.3, except that the enclosure and terminals locations are different. Instead of the standard enclosure, the printed circuit boards are enclosed in a metal frame equipped with a blank panel. Controls and electrical connections are accessible to the rear of the enclosure by removing a cover. The bottom of the frame is provided with two holes to accommodate 1/2-inch electrical conduit.

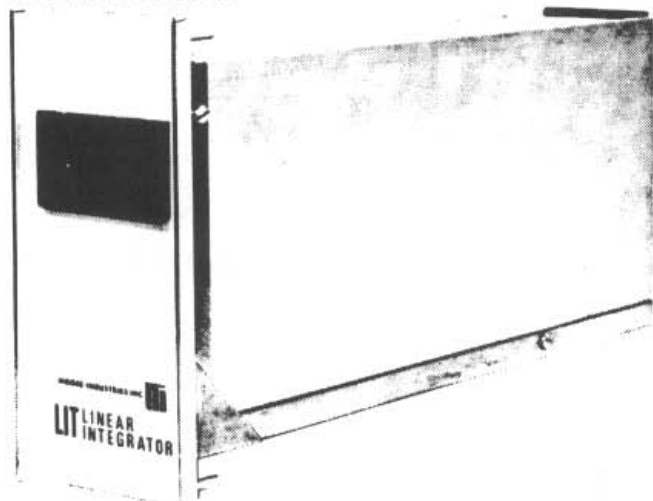

Panel Mounted Unit (PM)

## 1.4 SPECIFICATIONS

The specifications for the unit are listed in Table 1-1.

## 1.5 MODEL NUMBER EXPLANATION AND USE

MOORE INDUSTRIES' model numbers describe an instrument's type, functional characteristics, operating parameter, and include option identification. If all accompanying documentation of a unit is missing, the model number may be used to obtain technical information on the unit by following the example of Table 1-2. The model number for standard units, and units with CP and AB options, is located at the upper end of the terminal block stamped on a stainless steel tag. Plug-in units have their model number labeled on the inside of the grip extension to the front panel. PB units have the model number on top of the transmitter case. For explosion-proof units, the model number is stamped on a stainless steel tag on top of the enclosure and on the identification label on the unit within the enclosure. PM units model numbers are stamped on a stainless steel tag, visible when the rear safety cover is removed. To expose the model number on all NEMA box enclosures, open box and remove safety cover of the unit.

## 1.6 SERIAL NUMBER USE AND LOCATION

A complete history is kept on every MOORE unit. This information is keyed to the serial number. Whenever service data is required on a unit, it is necessary to provide the factory with a serial number as well as a model number. This identification is usually located with the model number (see paragraph 1.5 for location on equipment) except for plug-in units and explosion proof where the serial number is engraved into the PC board or stamped on a stainless steel tag respectively, and is usually preceded by the letter E.

**TABLE 1-1. UNIT SPECIFICATIONS**

**INPUT: (PROCESS)**

**Current:**

- 1-5 mA into 200 ohms nominal
- 4-20 mA into 50 ohms nominal
- 10-50 mA into 20 ohms nominal

**Voltage:**

- 0-5V, 1-5V standard
- 100K ohm load
- Other voltages optional

**INPUT: (COMMAND)**

**Sample:** 5 VDC @ 1 mA minimum 30 millisecond minimum wide pulse to initiate internally gated sample pulse

**Hold:** Return command input to 0 VDC

**Track:** Maintain 5 VDC @ 1 mA minimum to maintain unit in track mode

**FRONT PANEL ADJUSTMENTS:** Adjustable with multi-turn potentiometer

**Span:** With full scale input, adjusts output to 100% ±20% of selected output span

**Zero:** With minimum input, adjusts output to 0% ±10% of selected output span

**OUTPUT:** Operational amplifier feedback current source; output limited to 150% of maximum output range value

**Current:**

- 1-5 mA into 0-4800 ohm load
- 4-20 mA into 0-1200 ohm load
- 10-50 mA into 0-480 ohm load

**Voltage:** 1-5 VDC standard into 20K ohms minimum

**Ripple:** 10 mV P/P at maximum span and maximum load resistance

**Load Effect:** ±0.01% of span from 0 to maximum load resistance (current output)

**Output Modes: Sample & Hold — Standard:** The output level is made to match the input only after the initiation of the command input by a 30 millisecond minimum pulse. Unit will automatically hold output at the level of the input 1/10 second later. Optional holding at maximum input level during sample period.

**Track & Hold:** The output signal follows (tracks) the input signal continuously while command input is maintained. Returning the command input to 0 VDC will hold the output at the level that was the input at the instant of command input removal.

**PERFORMANCE:**

**Digital:**

Frequency Response: 0.5 Hz Track Mode

Decay Rate: None

Calibration Capability: ±1 part in 1000

**Ambient Temperature:**

Range: -20°F to +180°F (-29°C to +82°C)

Effect: ±0.01% out of above range

**Isolation:** Voltage output units have input negative side common to output negative side. Current output models have output negative side elevated above input negative side. Power input isolation is maintained on both AC and DC powered units.

**POWER INPUT:**

24 VDC, 45 VDC, ±10%

117 VAC, 210 VAC, 240 VAC, 50/60 Hz, ±10%

5 watts nominal

**Line Voltage Effect:** AC or DC: ±0.005%/1% line change

**CERTIFICATION:** Canadian Standards Association Listing

**WEIGHT:** Approximately 2 lbs. (908 grams)

**TABLE 1-2. MODEL NUMBER EXAMPLE**

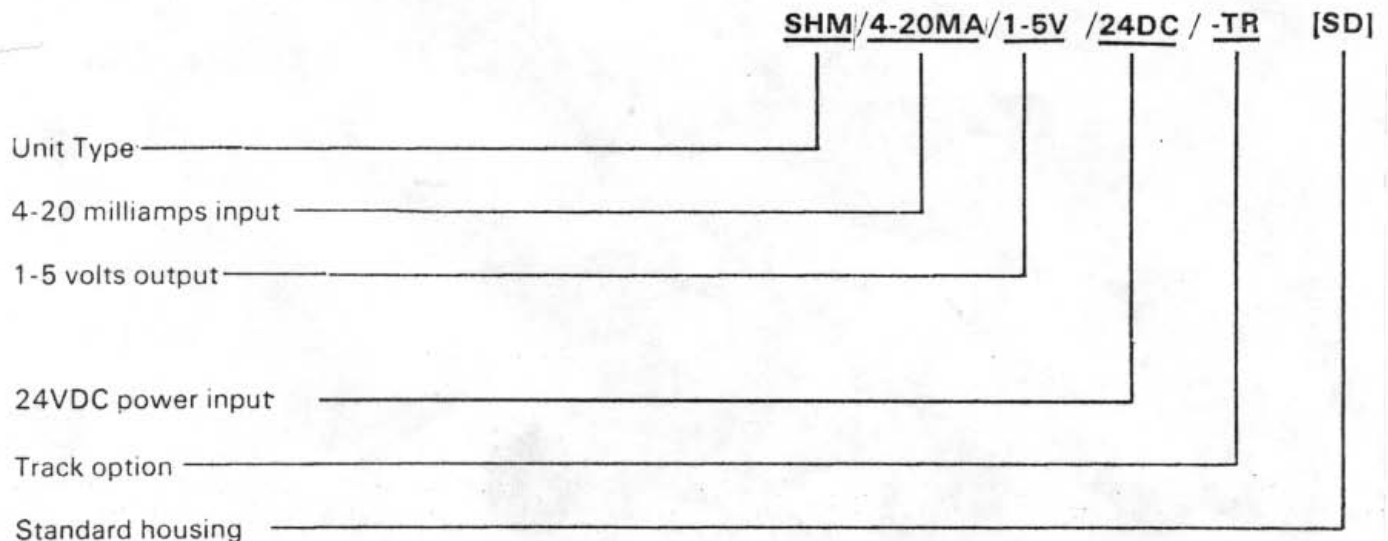



**TABLE 1-3. SHM ELECTRICAL OPTIONS**

OPTION DESCRIPTION	CODE
Input attenuation for signal input voltage exceeding specification — specify voltage (200V maximum)	AT
Contact closure command input	CC
Direct output — second output is derived from the input (Delta alarm systems only)	DO
Zero elevation — required on all transmitters for inputs exceeding standard zero adjustment capability (specify input for 0% out)	EZ
Power fuse on plug-in transmitter card ([PC] housing), 400 mA rating	FU
High-current (20 mA) 1-5 VDC output	HI
Peakpicking option — output holds at level corresponding to maximum input until exceeded or reset by external contact closure or pulse	PP
RFI Filter Terminal Assembly — adds Moore Industries patented integral filter terminal assembly which prevents radio frequency energy from entering standard aluminum case	RF
Reversed input/output current or voltage relationship	RO
Track and hold option — output tracks input until hold command given	TR
Two-wire transmitter excitation +35 VDC at 25 mA output to a two-wire field transmitter, one 4-20 mA only	TX

## CALIBRATION

### 2.1 GENERAL INFORMATION

This section provides information about unit calibration. Units with standard input and output levels are normally calibrated at the factory. After the unit is unpacked, general operating level checks of units is recommended. Usually these checks, specified in this section under calibration procedures, require little or no adjustments. If units are ordered with factory calibration option (FC), an exact calibration is performed at the factory, and red caps are placed on the controls. Adjustments should not be made in the field on these units unless a new range of input or output signal level is desired. Red caps should not be removed as a precaution against accidental adjustments.

### 2.2 CONTROLS DESCRIPTION AND LOCATION

The controls consist of ZERO and SPAN adjustments, located on the unit front panel. External controls are multiturn potentiometers that are adjusted with a blade screwdriver.

### CAUTION

**SCREWDRIVER BLADE MUST NOT BE MORE THAN 0.1 INCH ( 2.54 mm) WIDE. USE OF A WIDER BLADE MAY PERMANENTLY DAMAGE THE POTENTIOMETER MOUNTING.**

This type of potentiometer usually requires 20 turns of the shaft to move the wiper from one end of its range to the other. It is equipped with a slip clutch at either end of its travel to prevent damage if it is turned beyond the wiper stop. Usually a slight change in feel will be noticed when the clutch is slipping. However, if this change is not observed, either end can be reached by turning the shaft 20 turns in the desired direction. Controls are connected, so turning the shaft clockwise increases the quantity or makes it more positive, and turning the shaft counterclockwise has the opposite effect.

### 2.3 TEST EQUIPMENT AND TOOLS REQUIRED

Test equipment and tools required for calibration of the unit are described in Table 2-1; they are not

**TABLE 2-1. TEST EQUIPMENT AND TOOLS REQUIRED**

Equipment or Tool	Characteristic	Purpose
Screwdriver (blade)	Blade not wider than 0.1 inch (2.54 mm)	Front panel control adjustment
Voltage or Current Source	Must be capable of producing signal ranges defined by INPUT level requirements of purchased unit (see Table 1-1)	Simulate input signal levels
Command Signal Source	Must be able to deliver 1 mA at 5V	Simulate control signal input
DC Voltmeter	Must be accurate to within $\pm 0.05\%$ or better	Input signal monitoring (voltage inputs only). Output signal monitoring (voltage outputs only)
DC Milliammeter	Must be accurate to within $\pm 0.05\%$ or better	Input signal monitoring (current inputs only). Output signal monitoring (current outputs only)
Switching Network	Must be equipped with no-bounce circuits providing contact bounce less than 10 ms	Simulate control signal switching

supplied and must be provided by the customer at the installation or test site.

## 2.4 TEST EQUIPMENT SETUPS

Off-line calibration for all units require the same test equipment setups regardless of option or physical configuration. The hookup requirements and physical preparations may vary on some units. The following paragraphs define the general test setup and identify the units that require special attention for test preparation and connections.

### 2.4.1 General Test Equipment Setups

The test equipment setup required for calibration of all units is identical except for connection identification. Figure 2-1 shows the general test setup configuration. Connection nomenclature refer to terminal markings on the standard units with CP, AB, AA/TA, PM, and NEMA boxes mechanical options.

### 2.4.2 Plug-In Units Test Equipment Setup

Plug-in units equipment test setup is the same as the one shown in Figure 2-1, except that printed circuit board connections are identified in that figure by numbers in parentheses. Connection

identification numbers are etched in the component side of the PC board. Plug-in units inserted in a rack also use the test setup shown in Figure 2-1 with card rack terminal connections identified by numbers in parentheses. These include either the rack mount (RMR) or the surface mounted (SMR).

### 2.4.3 Explosion-Proof and PB Option Test Setup

Figure 2-2 shows the general test setup configuration for an explosion-proof enclosure or a PB option. Note that in the explosion proof configuration the protective housing must be opened and the unit removed to expose the connection block. Similarly, units with the PB configuration must be unplugged from the connection block in order to access the connections more effectively. Numbers in parentheses refer to terminal block numbers.

## 2.5 CALIBRATION

Units are calibrated and checked for proper performance at the factory before they are shipped. However, unless calibration was requested to a specific set of input-output values, the unit performance should be checked by the user before the unit is placed in service. Calibration consists of simulating the operative signal input and adjusting the unit to obtain the specified output.

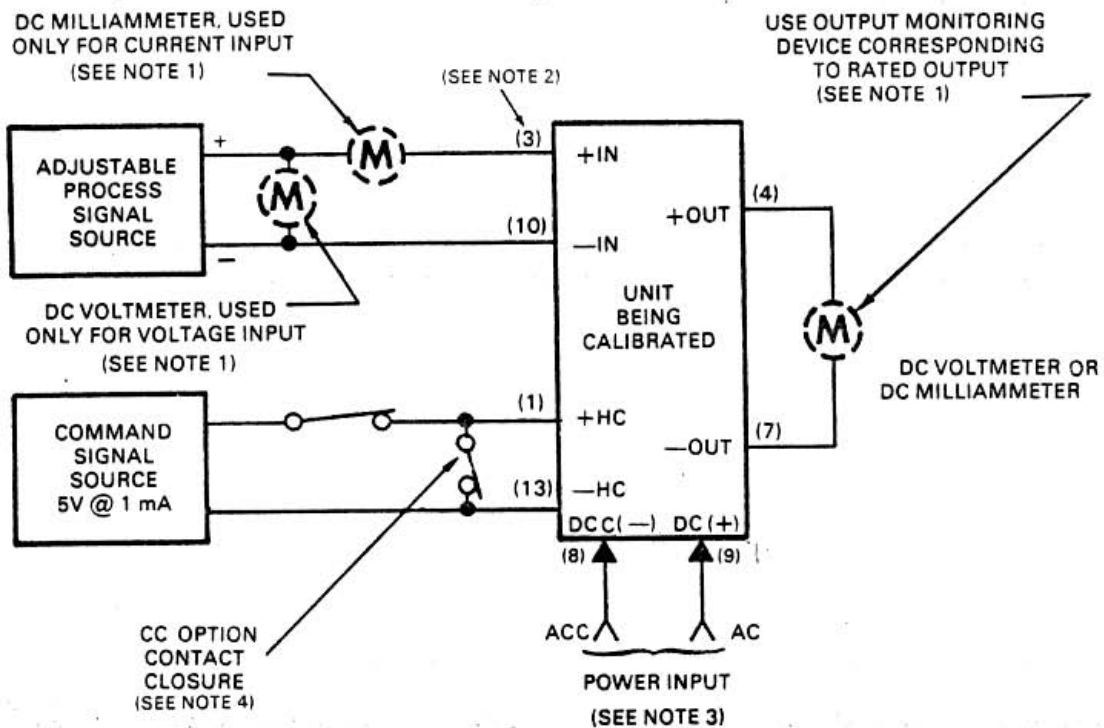

#### NOTES:

1. Accuracy of this instrument must be within  $\pm 0.05\%$  or better.
2. Numbers in ( ) apply to plug-in units only.
3. Either AC power or DC power is supplied but not both.
4. Input signal source switching must be equipped with no bounce circuits providing contact bounce less than 10 ms.

Figure 2-1. Test Equipment Setup For Calibration of Unit

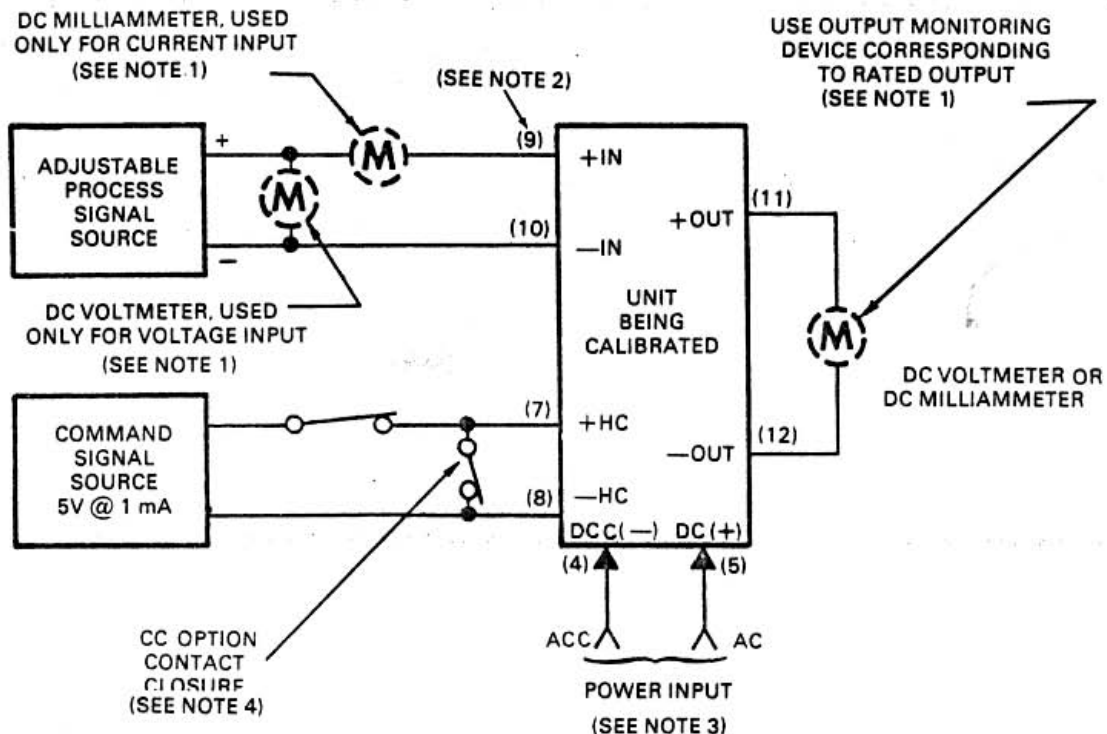

**NOTES:**

1. Input and output monitoring devices must be accurate to within  $\pm 0.05\%$  or better.
2. Numbers in ( ) refer to terminal block connector positions (see Figure 3-11).
3. Either AC power or DC power but not both.
4. Input signal source switching must be equipped with no bounce circuits providing contact bounce less than 10 ms.

**Figure 2-2. Test Equipment Setup for Calibration of Explosion Proof and PB Units**

**NOTE**

Adjustments should *not* be made in the field on units that are calibrated to values specified in the purchase order. Units that are calibrated at the factory to customer's specifications have protective caps over the SPAN and ZERO potentiometers; do NOT remove these caps.

One adjustable signal source, a contact closure (switch or relay) or a 5-volt signal source capable of delivering at least 1 mA, and input and output monitoring devices are required for calibration. The monitoring devices (current or voltage) must have an accuracy within  $\pm 0.05\%$  or better.

The calibration procedure for units without the TR option or PP option [(Sample-and-hold units) is slightly different from that for units with the TR (tracking) option (track-and-hold units)]. Therefore, two different sets of procedures are provided; use the one that corresponds to the configuration of the unit being calibrated, and ignore the other one.

**2.5.1 Calibration Procedure For Unit Without TR Option**

To calibrate a unit without TR option, or PP option, proceed as follows:

- a. Connect unit and test equipment as shown in Figure 2-1 or 2-2.
- b. Apply power input to the unit.

**NOTE**

Refer to paragraph 1.6 for information on how to use the model number to obtain the specified values of minimum and maximum inputs and outputs.

- c. Lower +HC signal to 0V (*open* the switch, CC option) and adjust the process signal source to the minimum value specified for the unit (1 mA, 4 mA, 10 mA, 1 VDC, or whatever the specified minimum input is for the unit).
- d. Momentarily raise +HC signal to +5 VDC, then lower to 0V (*close* and then *open* the switch CC option).
- e. Allow 0.1 second delay for the output to reach a steady value. Adjust the ZERO potentiometer to obtain 0% output (1 mA, 4 mA, 10 mA, 1 VDC, or whatever the specified 0% output is for the unit).

- f. Adjust the process signal source to the maximum input specified for the unit (5 mA, 20 mA, 50 mA, 5 VDC, or whatever the specified maximum input is for the unit).
- g. Momentarily raise the signal to +5 VDC, lower to 0V (close and then open the switch, CC option).
- h. Allow 0.1 second delay for the output to reach a steady value. Adjust the SPAN potentiometer to obtain 100% output.
- i. Repeat steps c through h until no further adjustment is needed.
- j. Adjust the process signal source to 25% of input specified for the unit.
- k. Repeat step g.
- m. Check that unit output reaches 25% of output specified.
- n. Adjust the process signal source to 50% of input specified for the unit.
- o. Repeat step g.
- p. Check that unit output reaches 50% of output specified.
- q. Adjust the process signal source to 75% of input specified for the unit.
- r. Repeat step g.
- s. Check that unit output reaches 75% of output specified.
- t. Remove the input signal sources and turn off the power input to the unit.
- c. Raise +HC signal to +5 VDC (close switch, CC option) and adjust the process signal source to the minimum value specified for the unit (1 mA, 4 mA, 10 mA, 1 VDC, or whatever the specified minimum input is for the unit).
- d. Adjust ZERO potentiometer to obtain 0% output (1 mA, 4 mA, 10 mA, 1 VDC, or whatever the specified 0% output is for the unit).
- e. Lower +HC signal to 0V (open switch, CC option) and observe that the output remains at the value adjusted for in step (d).
- f. Raise +HC signal to +5 VDC (close switch, CC option) and adjust the process signal source to the maximum input specified for the unit (5 mA, 20 mA, 50 mA, 5 VDC, or whatever the specified maximum input is for the unit).
- g. Adjust SPAN potentiometer to obtain 100% output (5 mA, 20 mA, 50 mA, 5 VDC, or whatever the specified maximum output is for the unit).
- h. Lower +HC signal to 0V (open switch, CC option) and observe that the output remains at the value adjusted for in step (g).
- i. Repeat steps c through h until no further adjustment is needed.
- j. Raise +HC signal input to +5 VDC (switch is closed, CC option).
- k. Adjust the process signal source to 25% of input specified for the unit.
- m. Check that unit output reaches 25% of output specified.
- n. Adjust the process signal source to 50% of input specified for the unit.
- o. Check that unit output reaches 50% of output specified.
- p. Adjust the process signal source to 75% of input specified for the unit.
- q. Check that unit output reaches 75% of output specified.
- r. Remove the input signal sources and turn off the power input to the unit.

### 2.5.2 Calibration Procedure For Unit With TR Option

To calibrate a unit with the TR option, proceed as follows:

- a. Connect unit and test equipment as shown in Figure 2-1 or 2-2.
- b. Apply power input to the unit.

#### NOTE

Refer to paragraph 1.6 for information on how to use the model number to obtain the specified values of minimum and maximum inputs and outputs.

### 2.5.3 Calibration Procedure For PP Option

To calibrate a unit with the PP option, proceed as follows:

- a. Repeat steps a, b of paragraph 2.3.2.
- b. Adjust process signal source to the minimum value specified for the unit (1 mA, 4 mA, 10 mA, 1 VDC, or whatever the specified minimum input is for the unit).
- c. Momentarily raise +HC signal to +5 VDC, then lower to 0V (close and then open the switch, CC option).
- d. Allow 0.1 second delay for the output to reach a steady value. Adjust the ZERO potentiometer to obtain 0% output (1 mA, 4 mA, 10 mA, 1 VDC, or whatever the specified 0% output is for the unit).
- e. Adjust the process signal source to the maximum input specified for the unit (5 mA, 20 mA, 50 mA, 5 VDC, or whatever the specified maximum input is for the unit).
- f. Allow 0.1 second delay for the output to reach a steady value. Adjust the SPAN potentiometer to obtain 100% output.
- g. Repeat steps (b) through (f) until no further adjustment is needed.
- h. Repeat steps (b) and (c).
- i. Adjust the process signal source to 25% of input specified for the unit.
- j. Check that unit output reaches 25% of output specified.
- k. Adjust the process signal source to 50% of input specified for the unit.
- m. Check that unit output reaches 50% of output specified.
- n. Adjust the process signal source to 75% of input specified for the unit.
- o. Check that unit output reaches 75% of output specified.
- p. Remove the input signal sources and turn off the power input to the unit.

# INSTALLATION AND OPERATION

## 3.1 MECHANICAL INSTALLATION

Units may be obtained in various physical configurations. Figures 3-1 through 3-10 show the outline dimensions and other installation requirements for the available configurations. Select the proper outline and dimension figure applicable to the unit purchased. Be sure to observe the applicable special procedures and precautions given with the illustration. Although the units are designed to operate in free air at quite a high ambient temperature, it is advisable, if possible, to mount the unit on a surface made of material that can serve as a heat sink. For a plug-in unit mounted in a rack, be sure that the rack has adequate ventilation.

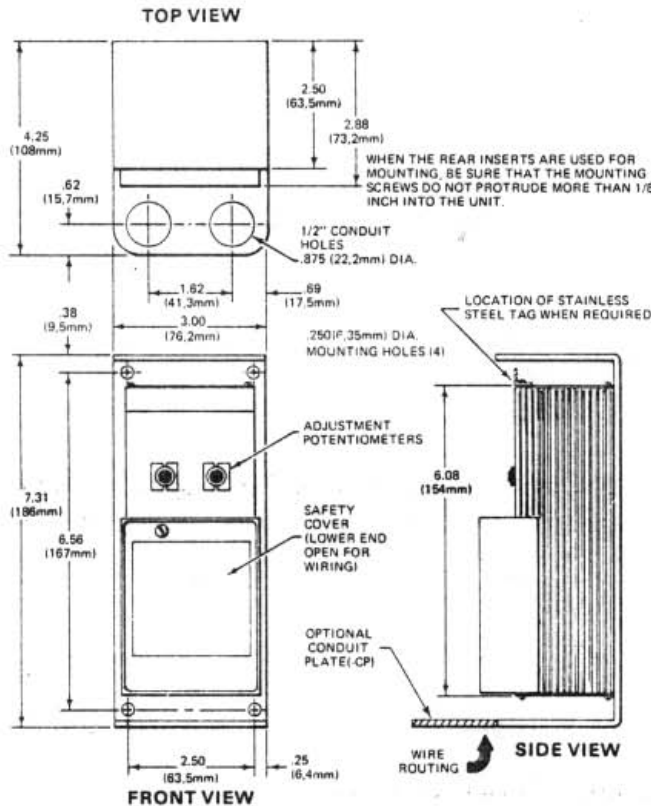

### NOTES:

1. Complete Model No. and Serial No. are permanently marked on identification plate located at upper end of terminal blocks.
2. When extra-compact mounting is required for rack or portable installation, C-shaped mounting bracket may be removed and two threaded inserts (located 4.00 inches apart) may be used for mounting, using 6-32NC machine screws.

Figure 3-1. Standard Unit and Unit with CP Option, Outline and Dimension

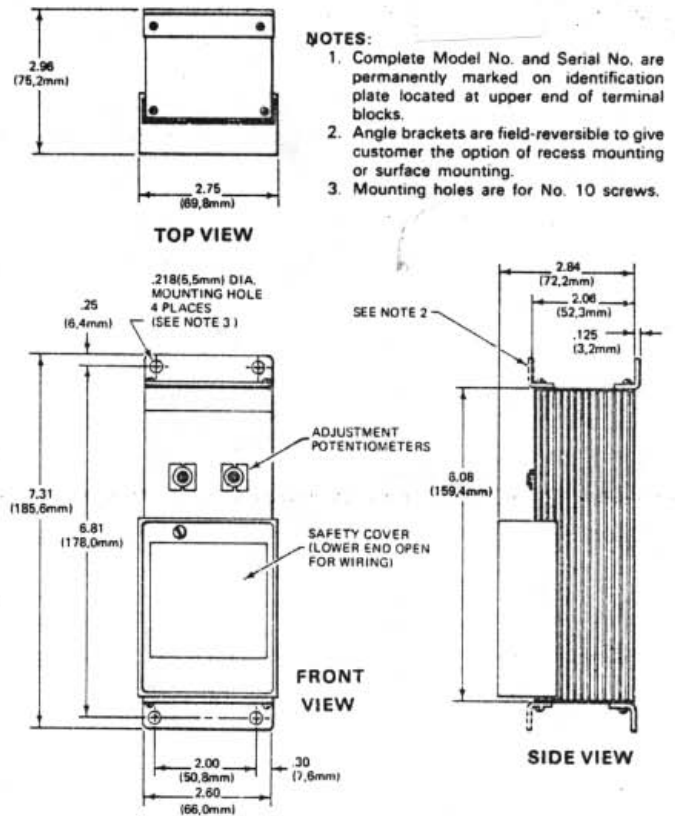

### NOTES:

1. Complete Model No. and Serial No. are permanently marked on identification plate located at upper end of terminal blocks.
2. Angle brackets are field-reversible to give customer the option of recess mounting or surface mounting.
3. Mounting holes are for No. 10 screws.

Figure 3-2. Standard Unit with Angle Brackets (AB) Option, Outline and Dimensions

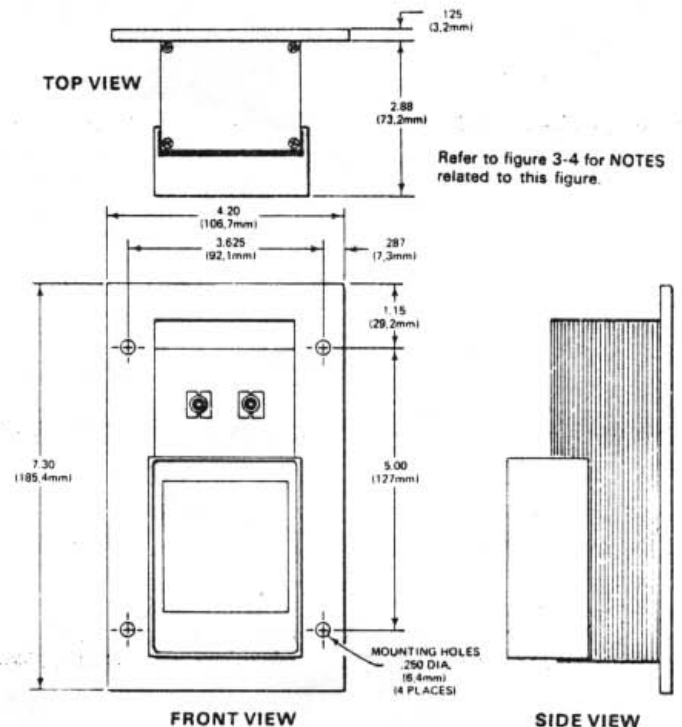

Refer to figure 3-4 for NOTES related to this figure.

Figure 3-3. Standard Unit, With Adaptor Plate (AA) Option, Outline and Dimensions

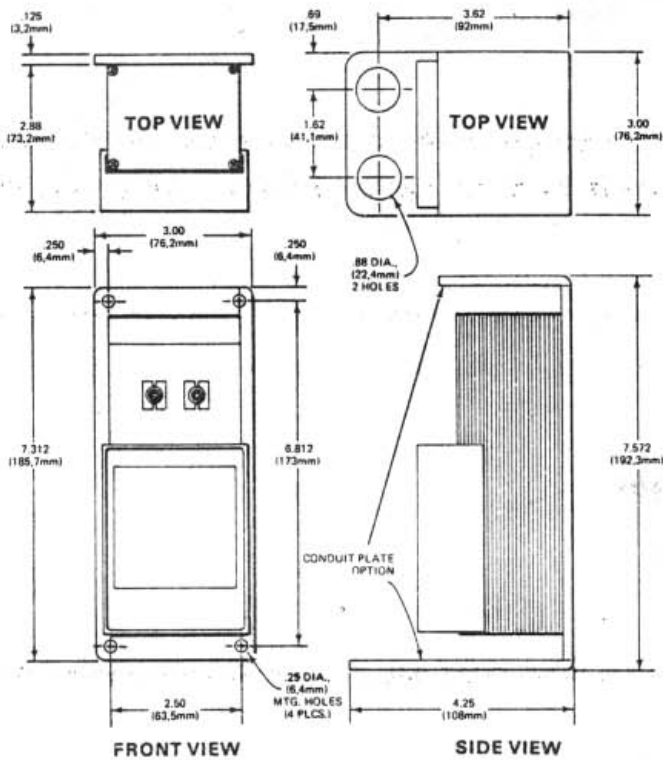

**NOTES:**

1. Use two threaded inserts (located 4.00 inches apart on back of standard transmitter) for mounting adapter plate to transmitter. Use 6-32 NC machine screws.
2. Unit to adapter plate mounting screws should not protrude more than 1/4" into the unit.

**Figure 3-4. Standard Unit, With Adaptor Plate (TA) Option, Outline and Dimensions**

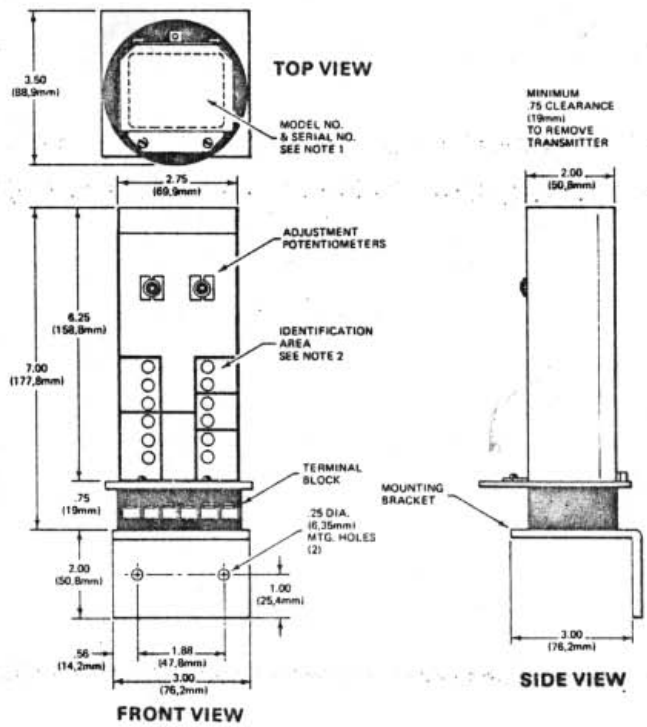

**NOTES:**

1. Identification area on top of unit case carries complete model number and serial number.
2. Identification area on front of transmitter case gives electrical connection information.

**Figure 3-5. Standard Unit With Plug-In SD Transmitter (PB) Option, Outline and Dimensions**

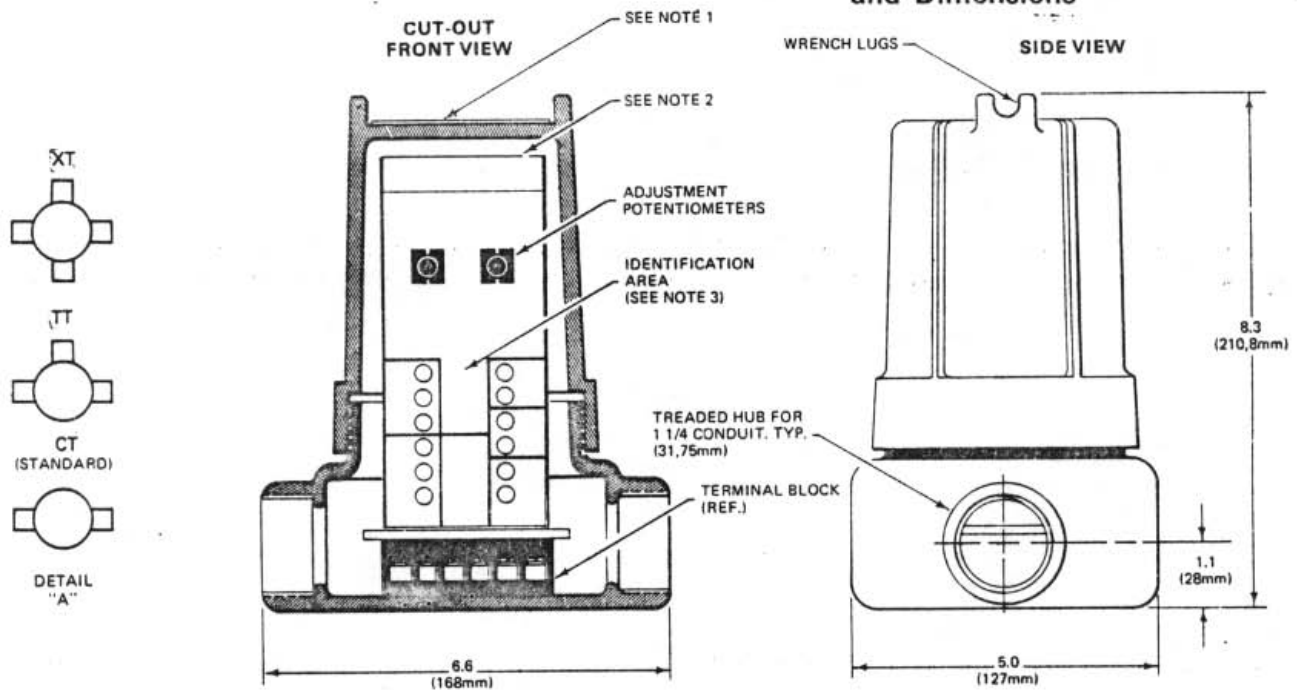

**NOTES:**

1. Top of cover has metal label carrying unit type (e.g., TCT, MVT) and equipment number (if any).
2. Identification area on top of unit case carries complete model number and serial number.
3. Identification area on front of unit case gives electrical connection information.
4. Standard "CT" housing (two conduit hubs) is shown above. Similar housings with three or four hubs is illustrated in detail A. Housings are cast aluminum alloy and meet NEMA specifications for Class I, Groups C and D and Class II, Groups E, F, and G.

**Figure 3-6. Standard Unit in Explosion-Proof Enclosure, Outline and Dimensions**



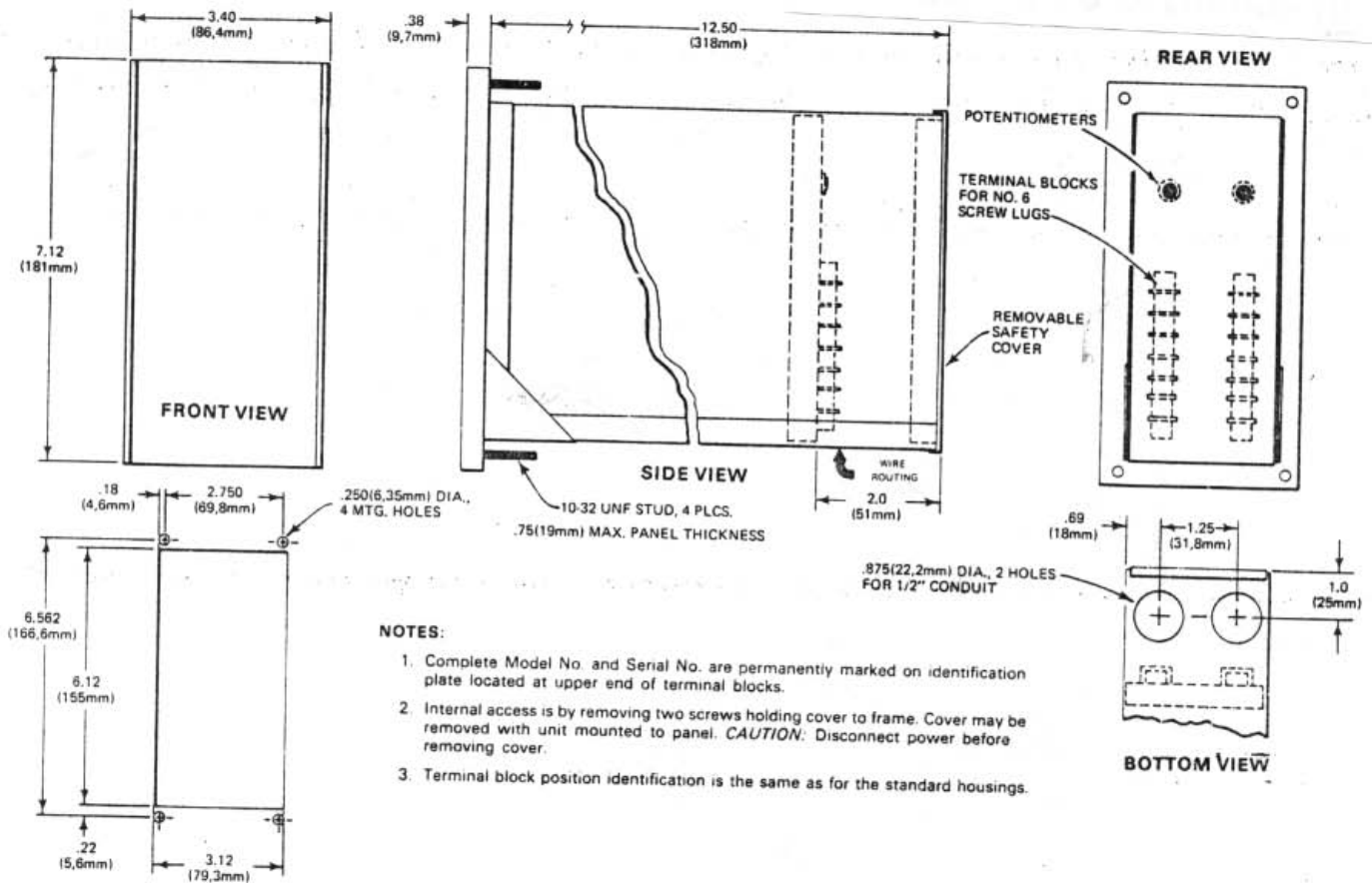

Figure 3-7. Standard Unit with Panel Mount Enclosure (PM) Option, Outline and Dimensions

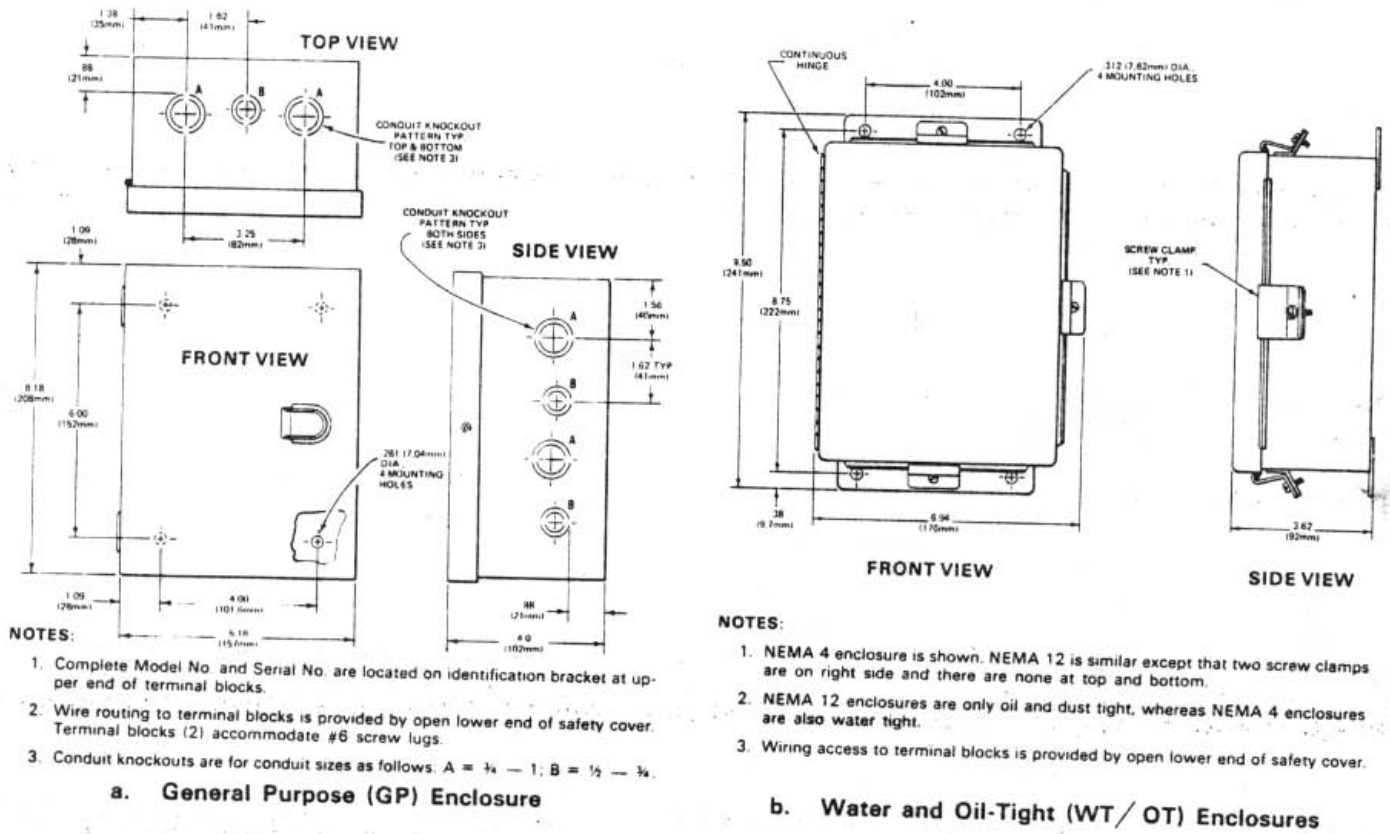
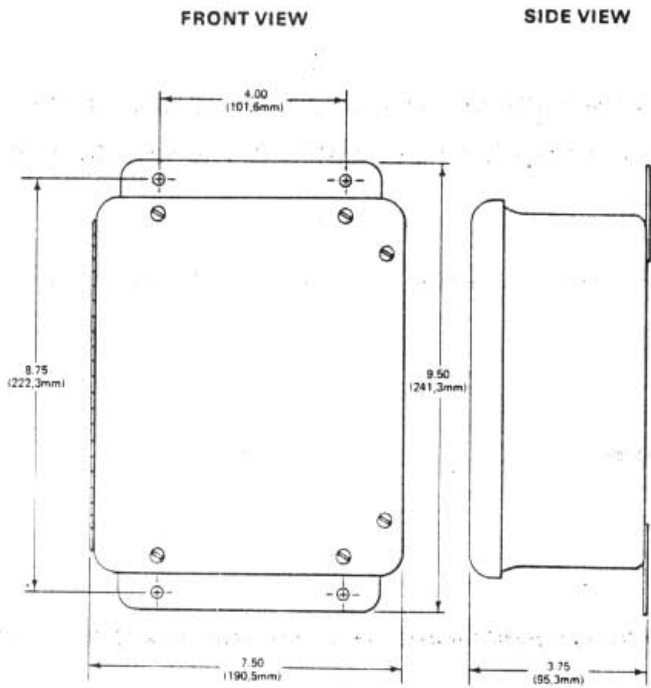

Figure 3-8. Standard Unit in NEMA Boxes, Outline and Dimensions



**NOTES:**

1. All exposed metal hardware is type 302 stainless steel. Boxes are hinged on the long side unless otherwise specified.
2. All boxes include a one piece closed cell neoprene gasket.
3. Standard color is machine tool grey. Boxes are molded from pigmented polyester resins with the color throughout the box wall for a maintenance-free installation.

**c. Corrosion-Proof (FG) Enclosure**

**Figure 3-8. Standard Unit in NEMA Boxes, Outline and Dimensions (Cont.)**

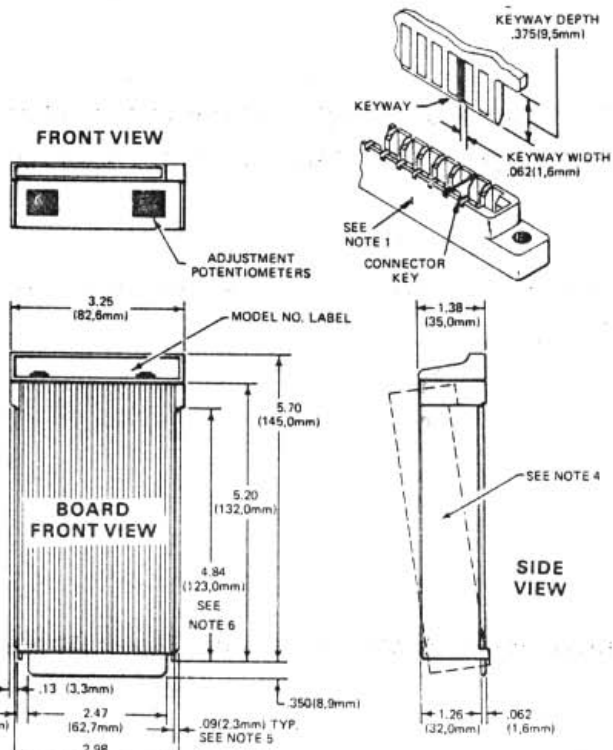

**NOTES:**

1. Connectors used must have contacts on .156 (3.96mm) centers, with contacts for both surfaces of board (recommended type: Viking part no. 2VK155/1-2).
2. Maximum card insertion depth in connector is .350 (8.89mm).
3. Minimum width of connector insertion slot is 2.470 (62.70mm).
4. Removable plastic safety cover, 2.800 (71.12mm) wide.
5. Maximum card edge-guide insertion depth is .09 (2.29mm). Guides must be non-conductive.
6. Card edge-guides cannot extend beyond here.
7. Card extender part no. 350-513-00 is available for testing unit while in operating position.

**Figure 3-9. Plug-In Unit, Outline and Dimensions**

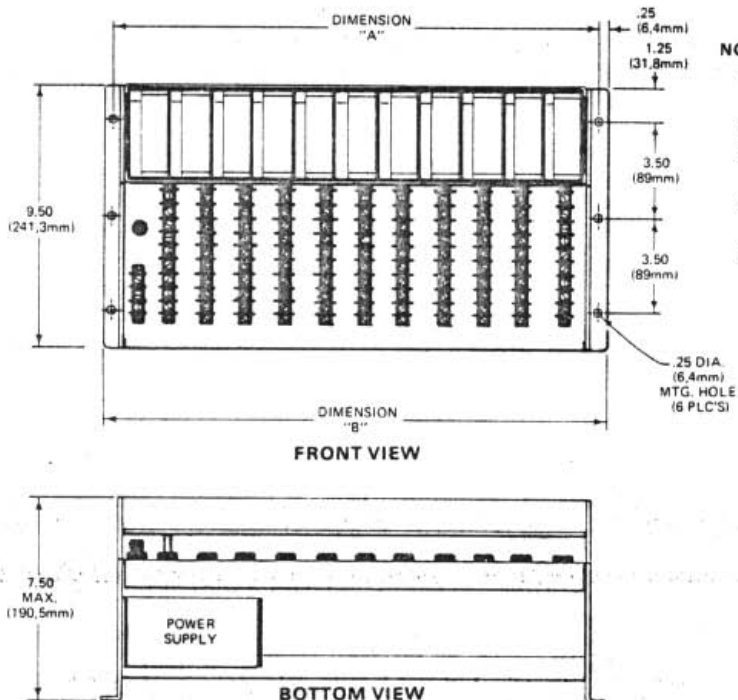

**NOTES:**

1. M.I.I. surface mounted card rack accommodates as few as 5, and as many as 15 plug-in units.
2. Empty positions may be closed by means of filler cards, P/N 350-213-00.
3. Connections are keyed to assure units will be plugged into proper position. Keying may be changed in the field if the system configuration changes.
4. Eleven position card rack is illustrated. Dimensions for mounting larger or smaller racks may be found in the table.
5. 24V power supply, shown, is capable of powering all models in card rack. Input specification, 117 VAC  $\pm$  10%, 50/60 Hz, approximately 40 watts.

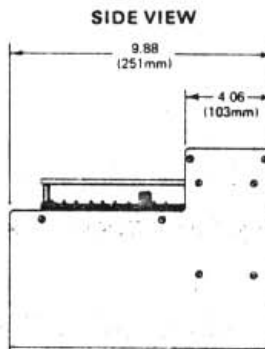

NUMBER OF POSITIONS	DIMENSION			
	A	mm	B	mm
5	9.19	233.4	9.69	246.1
6	10.62	269.7	11.12	282.4
7	12.06	306.3	12.56	319
8	13.50	342.9	14.00	355.6
9	14.94	379.5	15.44	392.2
10	16.38	416	16.88	428.8
11	17.81	452.4	18.31	465
12	19.25	489	19.75	501.7
13	20.69	525.5	21.19	538.2
14	22.12	561.8	22.62	574.6
15	23.56	598.4	24.06	611.1

**Figure 3-10. Surface Mounted Card Racks (SMR), Outline and Dimensions**

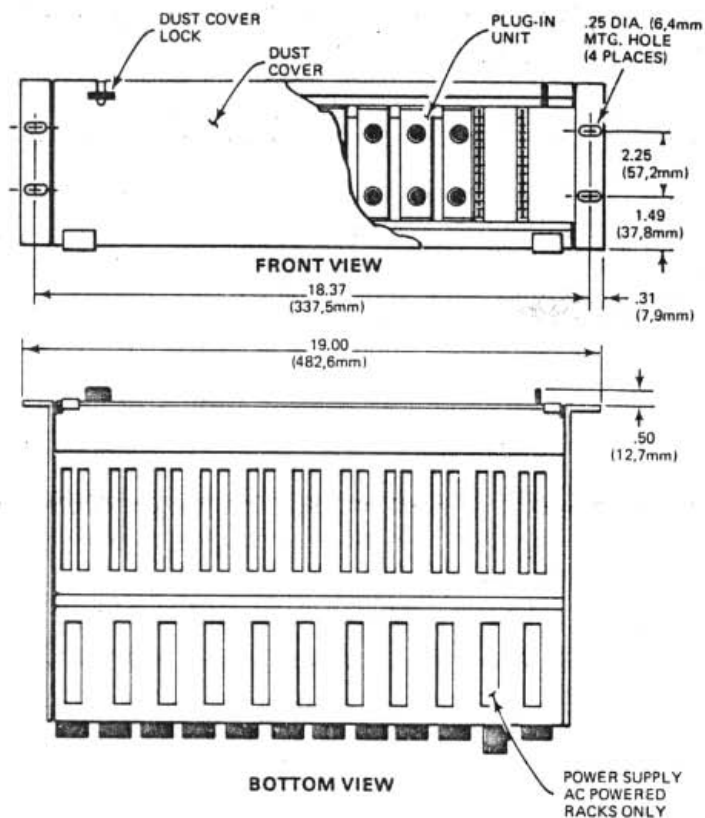

**NOTES:**

1. Connectors are keyed to assure units will be plugged into proper position. Keying may be changed in the field should the system configuration change.
2. This enclosure is designed to mount in a standard 19-inch rack with E.I.A. hole pattern.
3. Surface mounting card racks for use in NEMA type enclosures are also available. Contact factory for further details of card racks and card rack assemblies.
4. Barrier strip connectors are CSA approved.
5. Empty positions may be closed by means of filler cards, Part No. 350-213-00, which must be ordered individually in quantity required.
6. 24 volt power supply furnished capable of powering a typical complement of up to fifteen modules. Input specification 117 volts  $\pm$  10% 50/60 Hz approximately 40 watts.

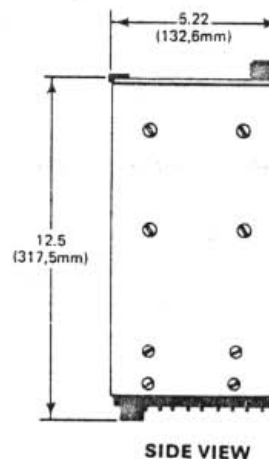

**a. Eleven-Position Card Rack**

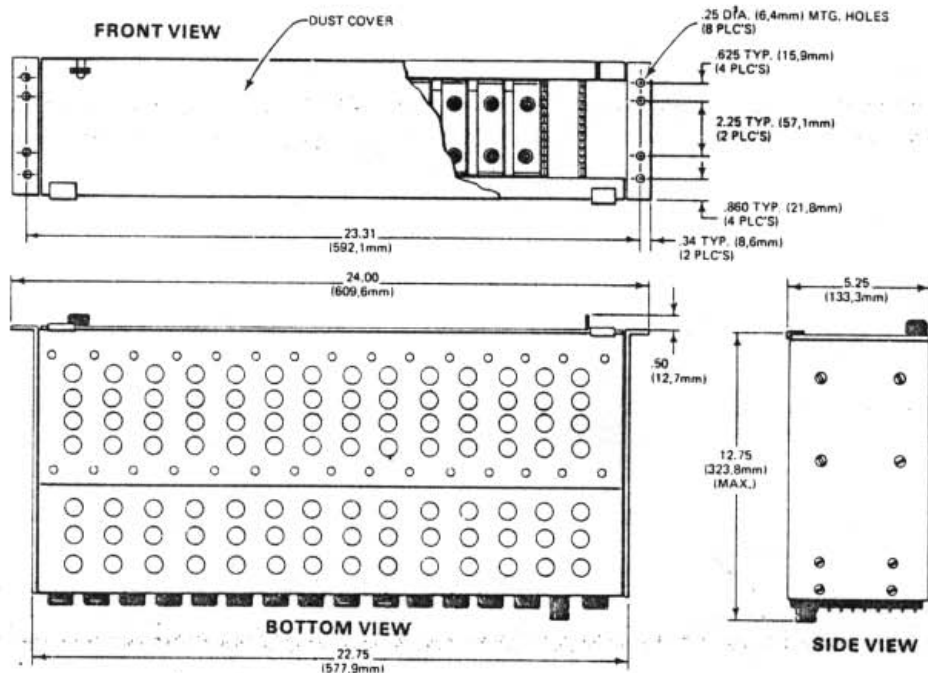

**b. Fifteen-Position Card Rack**

**Figure 3-11. Rack-Mounted Card Racks (RMR) Enclosure, Outline and Dimensions**

## 3.2 ELECTRICAL CONNECTIONS

All electrical connections to standard units are made to the terminal blocks on the unit. On plug-in units, the electrical connections are made to terminals on the mating connector for the unit. Terminals used for standard units and their options are defined in the following paragraph.

### 3.2.1 General Wiring Information

No special wire or cable is required for signal connections to the unit. To avoid transients and stray pickups, it is recommended that twisted conductors be used where they are run close to other services (such as power wiring). Electrical connections to the units fall into two major categories: connections to all standard units with terminal blocks, and connections to plug-in units and their associated enclosures.

*Wiring Information for All Standard Units With Terminal Strips and Blocks.* Standard units with terminal strips or terminal blocks have terminals supplied with 6-32 screws long enough to easily accommodate three spade-lug connectors. Standard units with snap-off plastic covers have an opening in the bottom of the cover. Dress all wiring to and from the terminals through this opening. Spade lug connectors are recommended for all wire terminations. Figure 3-11 illustrates the

terminal strip locations and identification for the standard units and the terminal block identifications for the explosion proof and PT configurations. Table 3-1 provides the complete labeling nomenclature for standard unit and any available electrical options. Terminal labeling appears next to the terminal it identifies on standard units. For PT and explosion proof units, terminal labeling is marked on the front of the unit housing with the referenced terminals identified numerically.

*Wiring Information for All Units in NEMA Boxes.* Units mounted in NEMA boxes are standard units with or without the options listed in Table 3-1. NEMA boxes for OT or WT options do not have conduit holes fittings or knockouts. Conduit access must be provided by fittings such as Myer Scru-Tite or equivalent.

General Purpose (GP) enclosures have conduit knockouts for various sizes of conduits from 1-inch down to 1/2-inch. Corrosion-Proof (FG) enclosures require special attention with ground connections. Since enclosure material is polyester resin, conduit cutouts may be cut with a punch or hole saw. Ground continuity may be obtained in two different ways. If a metal panel is used, ground can be made between the metal con-

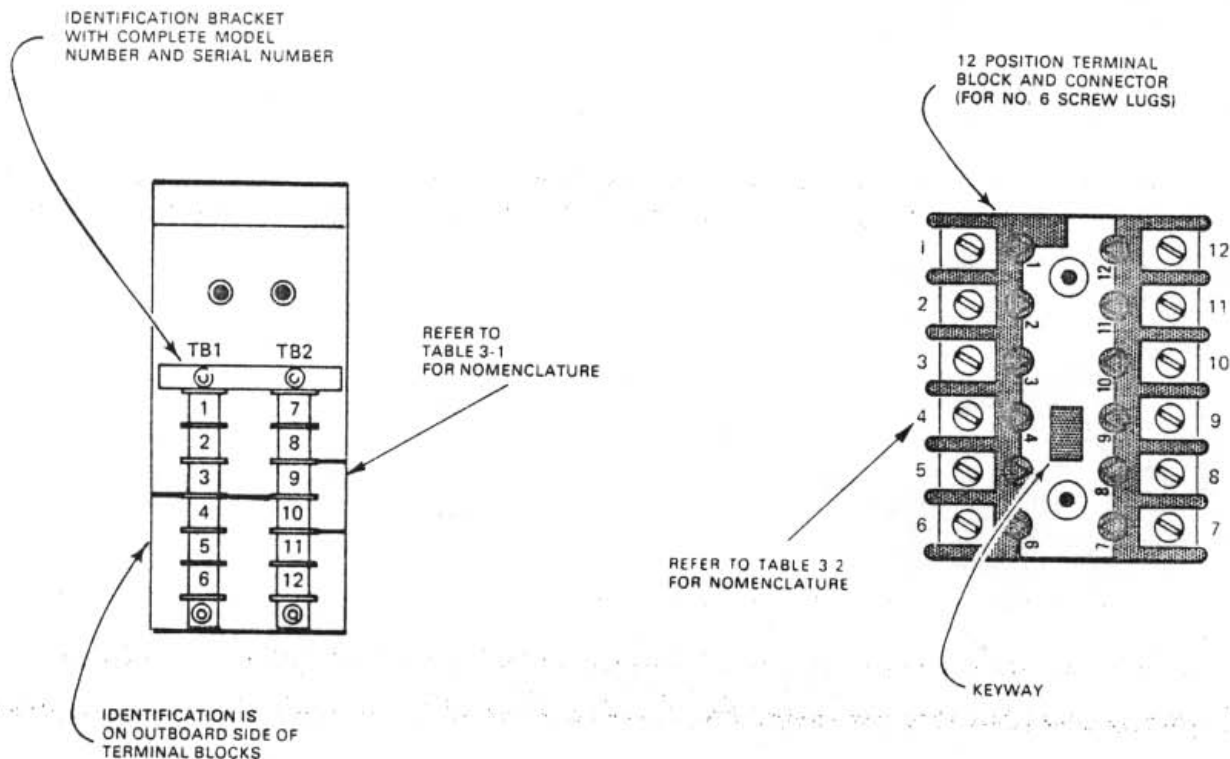

a. Standard Units

b. Units with EX or PB Configuration

Figure 3-11. Terminal Strips and Terminal Blocks Identification

**TABLE 3-1. TERMINAL NOMENCLATURE FOR SD AND EXPLOSION PROOF AND PB AND PT UNITS**

Options (Note 1)	Terminal Positions (See Figure 3-11)											
	1	2	3	4	5	6	7	8	9	10	11	12
None				DCC	DC	GND	+HC	-HC	+IN	-IN	+OUT	-OUT
AC				ACC	AC	GND	+HC	-HC	+IN	-IN	+OUT	-OUT
SC (Output)		SC	SC									
SC (Input) (Note 2)												
TR or PP (Note 3)												

**NOTES:**

1. Labeling shown here may be combined. The combination may include standard labeling and one or more options. Combinations of options may cause labeling positions to change, but nomenclature will remain as shown.
2. Terminal nomenclature not affected by this option. SC resistor is mounted across +IN and -IN terminals.
3. Terminal nomenclature not affected by this option.

**Legend:**

DC	+DC Power Input	+IN	Signal Input
DCC	-DC Power Input	+OUT	Signal Output
GND	Chassis Ground	SC	SC Resistor
AC	AC Power Input	±HC	Control Command Input
ACC	AC Power Return		

duit locknut and the panel at enclosure entry and exit. If the enclosure is used without the back panel, a jumper between the conduit entry and exit is necessary to maintain ground continuity. Remove snap-off plastic cover to access terminal strips.

*Wiring Information for Plug-In Units.* Plug-in units and card rack electrical connections are made to terminals on the mating connector for the unit or the card rack terminal strips. Figure 3-12 illustrates the terminal strip connections and their

numerical reference designator. Table 3-2 provides a complete terminal nomenclature for both Plug-In and Rack assemblies.

**3.2.2 Power Connections**

Units are designed to operate from either a DC or AC power source. Refer to paragraph 1.5 for information on how to use the model number to determine the type of power required.

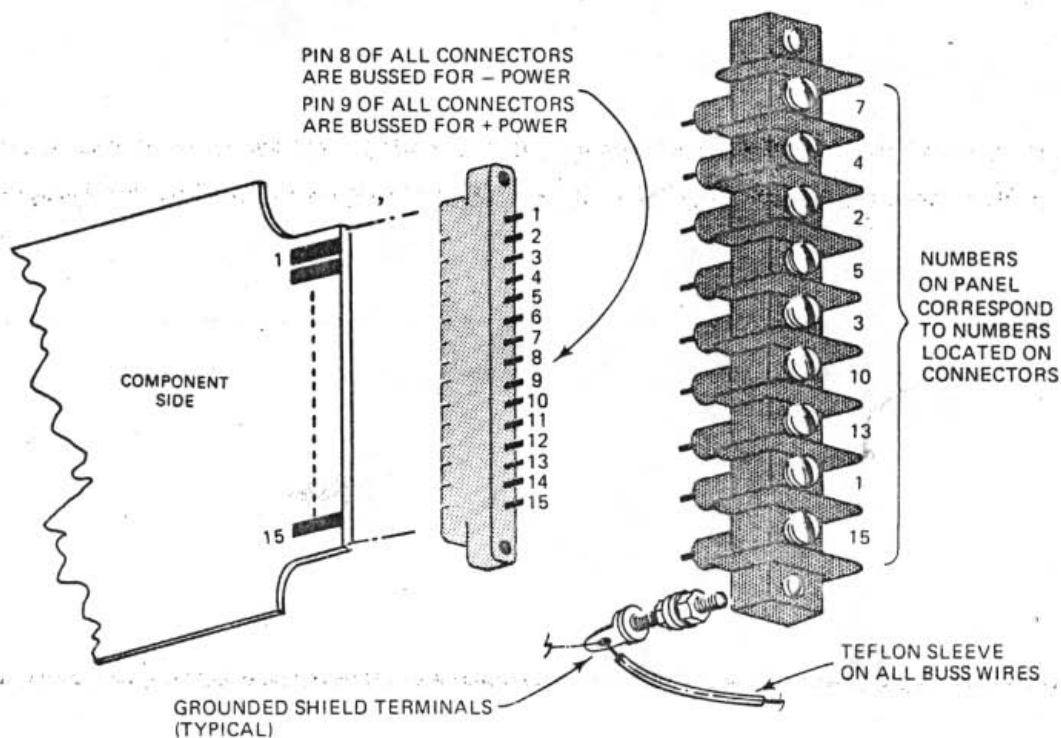

Figure 3-12. Plug-In Connectors and Terminal Strips Wiring and Identification

TABLE 3-2. CONNECTOR PINS AND TERMINAL ASSIGNMENTS FOR PLUG-IN UNIT AND CARD RACKS

Options	Terminal Position (See Figure 3-12)														
	1	2	3	4	5	6	7	8	9	10	11	12	13	14	15
None TR or PP	+HC		+IN	+OUT			-OUT	DCC	DC	-IN					-HC
SC (Output)		SC													SC
SC (Input) (Note)															

Keyways

NOTE: SC Input resistor is mounted across -IN and +IN terminals.

Legend:

DC	+DC Power Input	±IN	Signal Input
DCC	-DC Power Input	+OUT	Signal Output
GND	Chassis Ground	SC	SC Resistor
		±HC	Control Command Input

*DC-powered units.* On these units the DC terminal is connected to the + (positive) side of the source, and the DCC terminal is connected to the — (negative) side. The DC source should be regulated to within  $\pm 10\%$  of the nominal voltage and should be capable of delivering 5 watts.

*AC-Powered Units.* These units require 117 volts AC  $\pm 10\%$ , 50/60 Hz at 5 VA of nominal power or 220/240 VAC optionally. The AC terminal should be connected to the ungrounded or "hot" side of the supply, if possible, and the ACC terminal is connected to the common or neutral. The GND terminal is the mechanical case connection.

*Rack Power Connections.* Connect power input wires to the appropriately labeled terminals of the 3-terminal connector strip. The third terminal on strip is chassis ground.

### 3.2.3 Connections On Units With SC Option

On units with the SC (selectable current) option, connect the input selectable current resistor to the +IN and —IN terminals. Connect the output selectable current resistor to the terminals marked SC, or those specified in Table 3-1. The current range is marked on the body of each resistor. If provided, the selectable current resistors for a

plug-in unit should be mounted externally either at the terminal block of the card rack, or soldered to the appropriate terminals on the PC connector. See Table 3-2 for correct connections.

## 3.3 OPERATION AND PERIODIC OBSERVATION

Once calibrated and installed, the unit may be operated unattended. The only controls on the outside of the unit are the SPAN and ZERO potentiometers, which, after initial adjustments, need no further attention. There are no indicators on the unit. Because the circuit uses highly reliable solid-state components with no moving parts, the unit should operate virtually maintenance-free for a long period of time. However, if a malfunction should occur, refer to Section 5 for maintenance information.

A periodic check of input and output connections is recommended every six months to ensure continued dependability of operation.

A unit may become warm during operation, especially where the ambient temperature is rather high. This is perfectly normal and should not be a cause for alarm unless a malfunction is also observed.

## THEORY OF OPERATION

### 4.1 INTRODUCTION

This section describes the theory of operation of the unit. The description of each circuit is presented in sufficient detail so troubleshooting, if required, can be carried out intelligently and rapidly.

Components reference designators are listed here for both the standard and the plug-in models. The standard unit reference designator is listed first followed by the reference designator for the plug-in unit in parentheses and italics. If both reference designators are the same, only one is listed.

### 4.2 GENERAL FUNCTIONAL DESCRIPTION

The SHM consists of the functional elements illustrated in Figure 4-1. This figure also illustrates

both an AC operated power supply and a DC operated power inverter. Please note that a unit will have either the power supply or the inverter but not both.

The analog input is processed by an input buffer and fed to a comparator. This circuit compares the present state of the counter with the input signal. A sample command from the  $\pm$ HC inputs initiates counter operation according to several different options. As the counter counts up, the output of the D to A buffer follows until the comparator sees that both input and output are equal. The sample and hold controls then stop the counter and the output of the D to A buffer remains at that level. This signal is amplified through the output amplifier to produce the unit output.

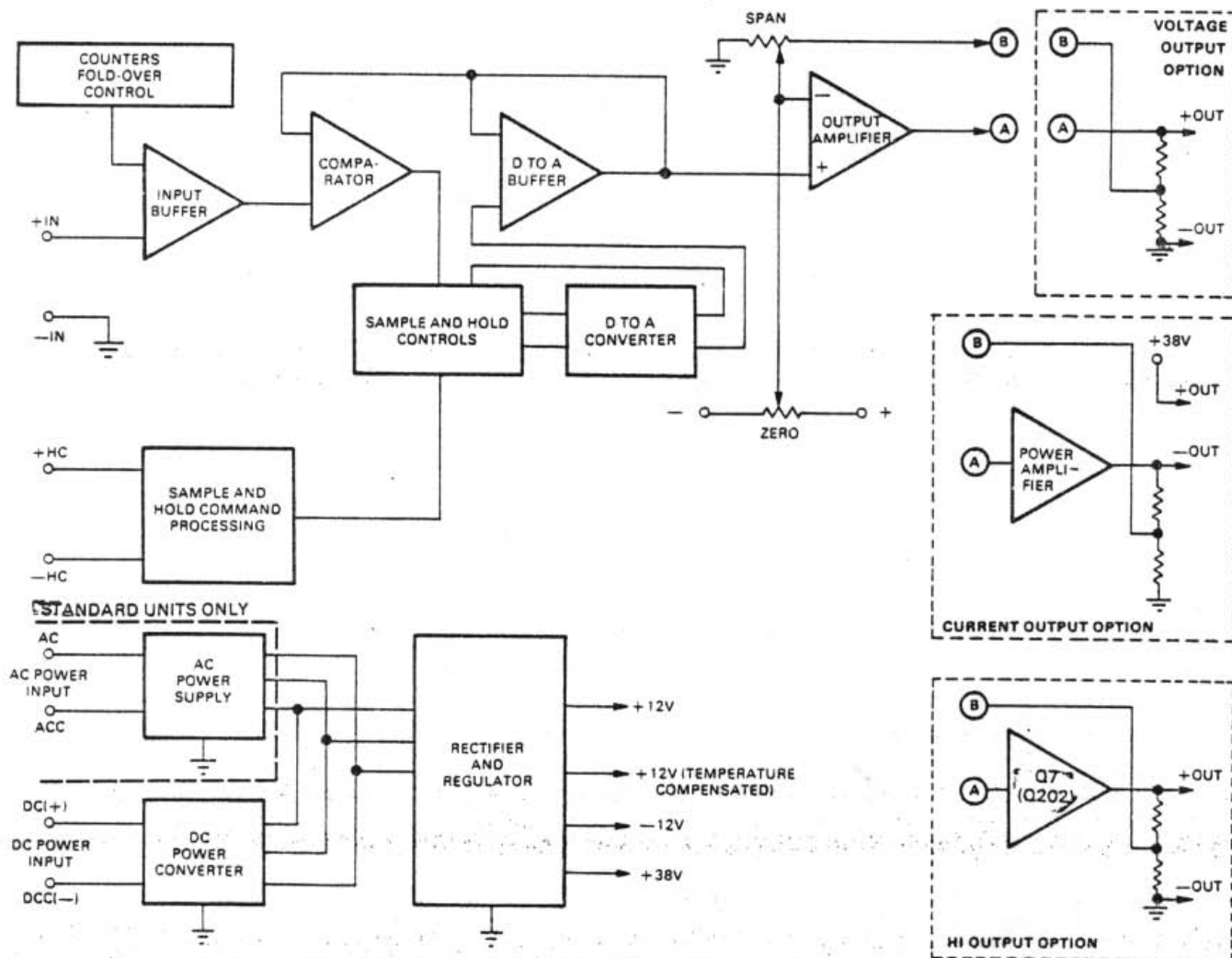

Figure 4-1. SHM Block Diagram



of the applied AC input. Finally the unit output power is generated by a power amplifier stage. Except where otherwise indicated, refer to drawing 165-401-00 (165-451-00), the main schematic diagram near the end of this manual, when reading these paragraphs.

#### 4.3 DESCRIPTION OF POWER INVERTER CIRCUIT

The power inverter is a transformer-coupled multi-vibrator oscillating at approximately a 3 KHz rate. Because the core of the transformer is saturated, a square wave of reasonably constant amplitude is generated.

The components of the power inverter are mounted on a printed circuit board attached to the main board for standard units and are mounted directly on the main board for plug-in units. Drawing 400-404-00 is the schematic diagram of the power inverter (PCA) used on a standard unit. When a standard unit is ordered for use with DC power, the power inverter is used instead of the AC source T2 shown on the FDT schematic diagram. The DC applied to the power inverter is converted to a square wave of approximately 3 KHz by Q1, Q2 (Q6, Q7), and the primaries of T1 (T2), functioning as a DC-to-AC inverter. Filter L1-C4 (C13) prevents the 3-KHz signal from getting back into the external DC source. CR1 (CR7) provides protection against damage from inadvertent application of DC of incorrect polarity. The square-wave output from center-tapped secondary 8-13 is applied to full-wave bridge, CR9 thru CR12 (CR4 CR5, CR10, CR11), and that from secondary 17-16 is applied to a full-wave bridge, CR4 thru CR7 (CR2, CR3, CR8, CR9).

#### 4.4 DESCRIPTION OF AC POWER SUPPLY CIRCUIT (Standard Units Only)

When AC power is applied, the power supply produces AC voltages of different amplitude (with respect to ground). These are applied to the rectifier and regulator, which develop regulated and unregulated DC as operating voltages for the unit.

The AC power supply circuit consists of a power transformer that produces two different AC outputs. Referring to the main schematic diagram, it is seen that VS1 is connected across the primary of power transformer T2 and suppresses transients that may be present on the power line. Each half of the center-tapped secondary of T2 produces 18 volts, and the other secondary produces 36 volts. The voltage from the center-tapped secondary is applied to PC2, and that from the other secondary is applied to full wave rectifier CR4 thru CR7 (CR2, CR3, CR8, CR9).

#### 4.5 DESCRIPTION OF RECTIFIER AND REGULATOR CIRCUIT

The rectifier accepts the outputs from either the AC power supply or the power inverter and produces unregulated positive and negative voltages (of equal value with respect to ground). The regulator reduces these voltages to the required operating values and regulates them against changes with load or line-voltage changes. Another rectifier produces a higher regulated output as operating voltage for the power amplifier. On all standard units, the components of the  $\pm 12V$  regulator circuits are mounted on a printed circuit board attached to the main board (PC2). The +30V rectifiers and regulators for the +30V supply are mounted on the main board.

The blue and violet leads from either PCA or AC transformer T2 are connected to a full wave rectifier CR4 thru CR7 (CR2, CR3, CR8, CR9). Capacitor C2 (C5) filters the output, while VR1 and CR2 (CR1) provide the regulation for the +30V power to the unit.

The center-tapped outputs of AC transformer T2 or PCA pins ABC are connected to a full wave rectifier CR9 thru CR12 (CR4, CR5, CR10, CR11). The pulsating DC is filtered and regulated by C202 (C7), C204 (C8), VR202 (VR2) for +12V and C201 (C9), C203 (C10), and VR201 (VR3) for -12V supplier.

#### 4.6 DESCRIPTION OF INPUT CIRCUIT AND WAVE SHAPER CIRCUIT

The input signal (which may be floating or not floating) is coupled by the transformer to the buffer comparator IC3 (IC5). For a direct coupled input, the transformer is not used and IC2 (IC4) with associated circuitry is added. This circuit level shifts the input signal so that the comparator, IC3 (IC5) will always see a zero crossing signal even if the input waveform is not. The output from the comparator produces a signal having a shape and amplitude suitable for driving the one-shot generator. This additional stage is necessary to improve the noise immunity and thus assure constant output pulses even in the presence of noise on the input signal. Additional shaping also provides a signal with sharp transitions so the one-shot generator will be uniformly and reliably triggered regardless of the input waveform, thus insuring constant accuracy of the unit. The comparator operates from the +12V and -12V supplies.

Operational amplifier IC3 (IC5) is used as a comparator with controlled hysteresis. The signal from IC2 (IC4) is applied to the inverting input (pin 2) of IC3 (IC5) and feedback is applied through R14 (R45) to the non-inverting input (pin 3).

(CR2) ensures that the output of IC3 (IC1) will never go below ground, a condition that could damage the CMOS components on the control card.

#### 4.8 CONTROL COMMAND CIRCUITS DESCRIPTION

The sample and hold control circuits consist of sample and hold command processing circuits and a control board. The sample and hold commands originate from the  $\pm$ HC terminals. The signal processing circuit consists of Q5 (Q3) and associated component. This circuit inverts the positive (+5V) control signal input to a negative going signal for use by the control board. If a contact closure (-CC) option is used, the signal conversion circuit is bypassed and the input is wired directly into the control board.

The control board has three different configurations. When the SHM unit is standard, the control board contains the sample and hold controls described in paragraph 4.8.1. When the SHM unit contains the tracking (TR) option, the control board consists of the circuits described in paragraph 4.8.2. When the SHM unit contains the peakpicker (PP) option, the control board consists of the circuits described in paragraph 4.8.3.

##### 4.8.1 Sample Mode Control Circuit Description

In a standard unit, control board PC3 (PC4) contains the sample mode circuits. Figure 4-2 functionally illustrates this circuit, while schematic 189-404-00 (189-453-00) gives a complete components and circuit connections diagram. When sample mode is used, jumpers J2 and J3 (J1, J4) are used to set up the response of IC3 (IC1). In this configuration as the input to the unit is higher than the stored value, the output of IC3 (IC1) goes high.

The clock generator shown on schematic 189-404-00 consists of an oscillator, unijunction transistor Q302, with R303 and C301 forming the RC network that controls a basic oscillator frequency

of 50 KHz. For plug-in unit the oscillator is mounted on the main board using transistor (Q1), with (R5) and (C2) forming the RC network. The basic oscillator clocks a JK flip-flop IC301 (IC402) through buffer transistor Q301 (Q2 on main board). Since both inputs to the flip-flop are high, the flip-flop toggles at every clock, producing a master clock output of 25 KHz at pin 8 of IC301 (IC402).

When the input to the SHM is higher than its output, IC303 (IC403) pin 12 is high. At the next clock pulse, D flip-flop IC303 (IC403) output pin 9 goes high forcing the exclusive OR gate IC302 (IC404) output low. This low is inverted by IC304 (IC401) at pin 4, providing a high at the input to pin 2 of D flip-flop IC303 (IC403).

When the negative-going sample pulse is received at PC3 (PC4), pin 3 (1), IC304 pin 3 (IC401, pin 11) goes high, clocking the D flip-flop at IC303 (IC403) pin 3. The Q output at pin 5 now follows the input and a high is propagated to IC301 (IC402) pin 14 and to IC304 pin 2 (IC401 pin 12), disabling this gate. The condition on gate IC304 (IC401) prevents any new sample pulse from inadvertently clocking the D flip-flop before the proper conditions exist. At the next clock time, IC301 (IC402) pin 13 goes low enabling gate IC304 at pin 12 (IC401 at pin 1) to pass each succeeding clock to the PC3 (PC4) output pin 6 (4), clocking the up/down counters in the D/A converter board PC2 (PC3) (refer to paragraph 4.9) counts up.

When the output counts higher than the input, PC3 pin 2 (PC4 pin 6) goes low. Before a clock at IC303-11 (IC403-11) can lower D flip-flop output, exclusive OR gate IC302 (IC404) output goes high. This condition provides a toggling signal to JK flip-flop IC301 (IC402) at pin 3 and a low resetting signal to D flip-flop IC303 (IC403) pin 2. When the negative excursion of the clock occurs, JK flip-flop IC301 (IC402) is triggered at pin 1. The flip-flop now toggles, forcing pin 13 high, disabling gate IC304 (IC401) and removing the clock from PC3 (PC4) output pin 6 (4). At the same time the high state of JK flip-flop IC301

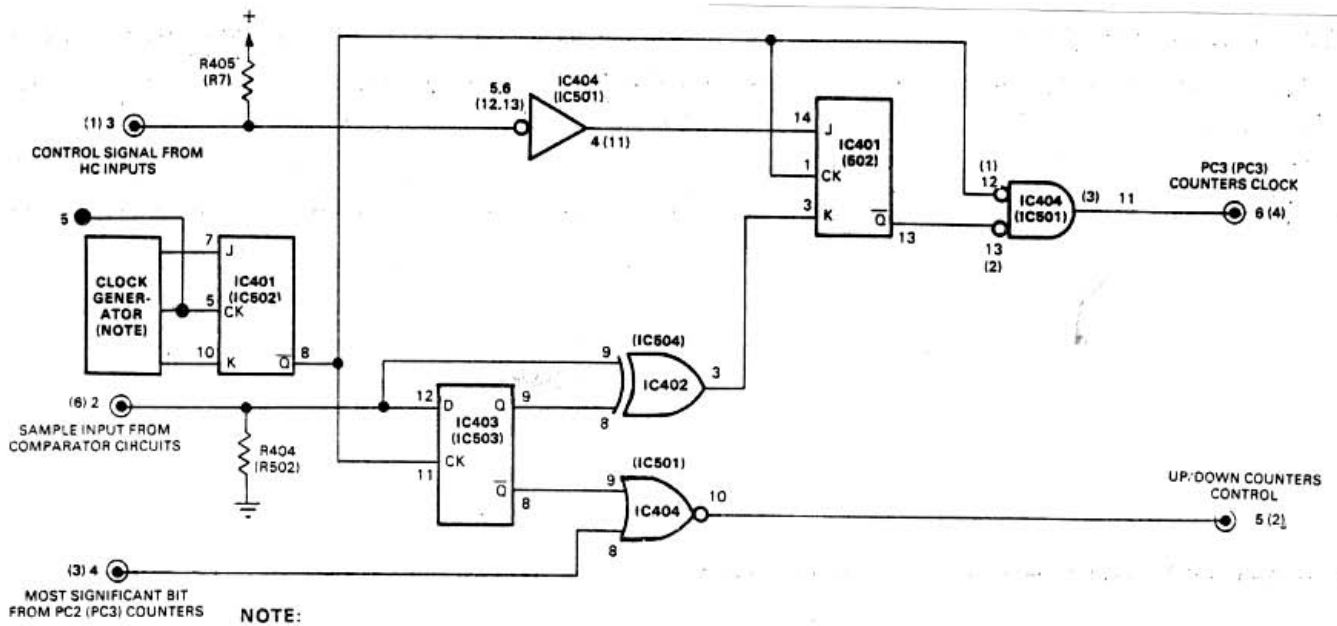

NOTE:  
1. Clock generator is mounted on main board in plug-in units, resulting in a different PC5 input connection.

Figure 4-3. TR Option Circuits, Simplified Logic Diagram

capacitors shown on the main schematic are used as spike suppressors to prevent superfluous triggering of the IC chips.

#### 4.8.2 Tracking (TR) Mode Control Circuit Description

In a unit with TR option, PC3 (PC4) is replaced by a TR control circuit on board PC4 (PC5). This control circuit enables the SHM to track the input whenever the track command is present and to hold the output to the level of the input at the time the track command is removed. This condition requires jumpers J2 and J3 (J1, J4) to be used at the input to IC3 (IC1). Figure 403 functionally illustrates this control circuit while schematic 189-405-00 (189-454-00) gives a complete components and circuits connection diagram.

Control timing is effected by a  $\overline{25\text{ KHz}}$  clock from the clock generator. This circuit, shown on schematic 189-405-00 for standard units, consists of an oscillator, unijunction transistor Q402, with R403 and C402 forming the RC network that controls a basic oscillator frequency of 50 KHz. Plug-in units use unijunction transistor Q1, with R5 and C2 forming the RC network, all of which are mounted on PC1. The basic oscillator clocks a JK flip-flop (IC501 pin 11) IC401 (IC502) through buffer transistor Q401 (Q2). Since both inputs to the flip-flop are high, the flip-flop toggles at every clock, producing a master clock output of 25 KHz at pin 8 of IC401 (IC502). As the SHM is storing,

no control signal is received and PC4 pin 3 (PC5 pin 1) is high forcing IC404 pin 4 (IC501 pin 11) low, providing a low signal to IC401 (IC502) pin 14 (J input). As the input to the SHM goes lower than its output, the J2, J3 (J1, J4) jumper configuration forces the output of IC3 (IC1) to be low, and consequently the sample input of PC4, pin 2 (PC5 pin 6) is low. This condition, before IC403-11 (IC503-11) is clocked, forces the output of IC402 (IC504) to go high, and IC401 (IC502) pin 3 is high. As the negative clock excursion occurs on pin 1 of IC401 (IC502), the flip-flop resets and IC401-13 (IC502-13) goes high blocking any new clocks to the counters. At the beginning of the next clock, IC402 (IC503) triggers and the exclusive OR gate IC402 (IC504) pin 3 returns to a low state. As PC4 pin 2 (PC5 pin 6) is low, IC403 (IC503) pin 8 goes high when IC403 (IC503) pin 11 is clocked. The high state of IC403-8 (IC503-8) forces IC404-10 (IC501-10) to go low, providing a down clock indicator to the counters on PC2 (PC3).

When the negative-going track command is received at pin 3 (1), IC404 pin 4 (IC501 pin 11) goes high. At the next clock sets IC401 (IC502), pin 13 goes low and clock output gate IC404 (IC501) is enabled to provide the clocks to the counters on PC2 (PC3), and the output is clocked down to the input level. When the output of the SHM goes lower than the input, IC3 (IC1) output goes high and consequently PC4 pin 2 (PC5 pin 6) goes high. Again, IC402-3 (IC504-3) output tem-

porarily goes high before the next clock's positive excursion triggers IC403 (IC503). The next negative excursion of the clock resets IC401 (IC502) and IC404 pin 13 (IC501 pin 2) goes high blocking any new clocks to the counters on PC2 (PC3). When the positive excursion of the clock occurs, IC403 (IC503) pin 9 goes high, forcing IC402-3 (IC504-3) low. The up or down clocking of the D/A converter is controlled by IC404-10 (IC501-10). While the sample input at pin 2 (6) is high, IC403 (IC503) pin 8 is low. If the D/A counters have not been filled, PC4 pin 4 (PC5 pin 3) is low forcing IC404-10 (IC501-10) to go high and the D/A counters on PC2 (PC3) will continue counting up. If the D/A counters have topped out, PC4 pin 4 (PC5 pin 3) is high and IC404-10 (IC501-10) will go low forcing the counters to count-down. If the sample input at PC4 pin 2 (PC5 pin 6) goes low, IC403 (IC503) pin 8 is high and IC404-10 (IC501-10) is low, forcing the D/A counters on PC2 (PC3) to count-down.

#### 4.8.3 Peakpicker (PP) Mode Control Circuits Description

In a unit with a PP option, standard board PC3 (PC4) is replaced by board PC5 (PC6) that contains the peakpicker control circuits. These circuits allow the SHM output to hold until the input goes

above the output signal. A control from the HC terminals forces the SHM into a sample mode. In this option the comparator circuits of IC3 (IC1) on PC1 use J1 and J4 (J2, J3) jumpers. This configuration causes IC3 (IC1) pin 6 to go high whenever the input to the SHM is lower than its output. Conversely when the input is higher than the output or stored value of the SHM, IC3 (IC1) pin 6 is low.

When the input to the SHM is higher than the stored value, the sample input from the comparator circuit is low, setting PC5 pin 2 (PC6 pin 6) low. At the next clock time, IC503 (IC603) pin 9 goes low. If the D/A counters have not been filled, PC5 pin 4 (PC6 pin 3) is low. This condition forces IC504-10 (IC601-10) to go high, and the counters on PC2 (PC3) will continue counting up at receipt of clocks. If the D/A counters have topped-out, PC5 pin 4 (PC6 pin 3) is high and IC504-10 (IC601-10) will go low forcing the counters to count down at the next clock time. The low state of IC503-9 (IC603-9) also forces IC502-4 (IC604-3) high, providing a low at K input to flip-flop IC501 (IC602) pin 3, and a high at the J input (pin 14) to the same flip-flop. At the next clock time, IC501-13 (IC602-13) goes low, enabling clock control gate IC504 (IC601) that provides clocks to PC5 pin 6 (PC6 pin 4) for

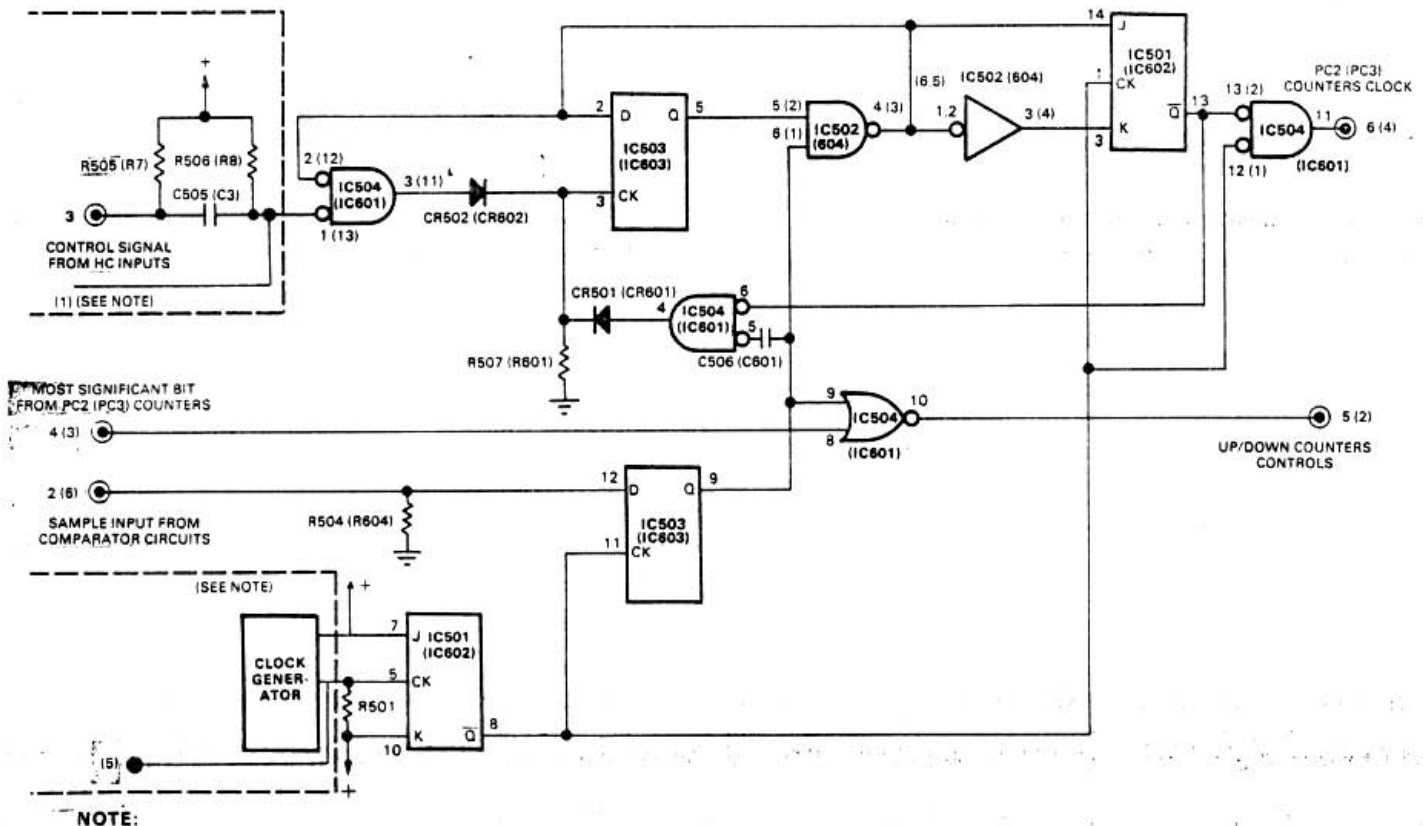

NOTE:

1. On plug-in units resistors R7, R8 and capacitor C3 and clock generator are mounted on the main board, resulting in different inputs on PC6.

Figure 4-4. Peak-Picker Circuits, Simplified Logic Diagram

counter triggering. The high state of IC502 pin 4 (*IC604 pin 3*) is applied to IC504 pin 2 (*IC601 pin 12*), locking out any sample commands during the counting sequence.

When the counters have counted up to the output signal value, IC3 (*IC1*) output goes high forcing IC503 (*IC603*) pin 12 high. At the next clock time, IC503 (*IC603*) pin 9 goes high forcing IC502 pin 4 (*IC604 pin 3*) low. This condition provides a reset signal to both inputs to JK flip-flop IC501 (*IC602*), enables the input control gate IC504 at pin 2 (*IC601 pin 12*), and holds a low on the input to D flip-flop IC503-2 (*IC603-2*). The high state of IC503 (*IC603*) pin 9 also forces IC504 (*IC601*) pin 10 to go low, providing a count-down indicator to the counters through PC5 pin 5 (*PC6 pin 2*). At the next clock time the reset signal on JK flip-flop IC501 (*IC602*) disables IC504-11 (*IC601-3*) stopping the clocks to the counters through PC5 pin 6 (*PC6 pin 4*). The counters now stop counting and the control circuit holds until either IC3 (*IC1*) comparator input changes or a control signal from HC or CC inputs at PC5 pin 3 (*PC6 pin 1*) occurs.

If the input to the SHM is below the stored or output value [IC3 (*IC1*) of PC1 output is high], and the stored value is to be brought down to the input value, a sample command is received at PC5 pin 3 (*PC6 pin 1*). At that time pin 2 of D flip-flop IC503 (*IC603*) is low, while the output pin 5 is high. When PC5 pin 3 (*PC6 pin 1*) goes low, flip-flop output pin 5 goes low forcing IC502-4 (*IC604-3*) high and locking-out all other inputs from PC5 pin 3 (*PC6 pin 1*) by the high state of IC504 pin 2 (*IC601 pin 12*). The high state of IC502-4 (*IC604-3*) also provides a setting signal to the input of JK flip-flop IC501 (*IC602*). At the next clock time IC501 (*IC602*) pin 13 goes low, enabling IC504-11 (*IC601-3*) to clock the counters on PC2 (*PC3*). Since PC5 pin 2 (*PC6 pin 6*) was high due to the state of comparator IC3 (*IC1*) on PC1, the D flip-flop IC503 (*IC603*) at pin 12 clocked this high state to IC504 (*IC601*) pin 9 forcing a down counter indicator out of PC5 pin 5 (*PC6 pin 2*). The control circuit now waits for the comparator IC3 (*IC1*) to detect that the output has gone lower than the input. When the output goes one bit below the input, the comparator detects this condition and PC5 pin 2 (*PC6 pin 6*) goes low. This condition forces PC5-5 (*PC6-2*) high allowing the up/down counters to count up. The counter now counts up one bit higher than the input level then stops as described above.

#### 4.9 DIGITAL TO ANALOG CIRCUITS DESCRIPTION

The Digital to Analog (D to A) circuits mounted on a separate board, PC2 (*PC3*), converts the digitalized sampling signal from the control board to an equivalent analog signal. The D to A circuit consists of 3 four-bit cascading up-down counters IC201, IC202, IC203 (*IC301, IC302, IC303*) and a resistance ladder network. The counters are controlled by signals from the control board, either PC3, PC4 or PC5 (*PC4, PC5 or PC6*). Each set bit develops a voltage across its respective voltage dividing resistor network. Since the network's outputs are connected in series, the resistances are additive. When the counters are full, PC2 pin 3 (*PC3 pin 33*) goes high, providing a control signal to the control board. The output of the D to A converter issues from the top of the resistance ladder, at the most significant bit side of the counters, providing a sum of all bits to the noninverting input of IC2 (*IC3*). Buffer IC2 (*IC3*) is a one-to-one amplifier that isolates the output of the D to A circuits from the output amplifier stage.

A counter reset circuit is also included on this board. The circuit consists of Q201 (*Q301*) and associated components. When power is applied to the SHM, capacitor C201 (*C301*) charges through R201 (*R327*). During this time, Q201 (*Q301*) is off and a high signal appears at the reset input to the counters, initializing these components. When the capacitor charges to 0.7V, Q201 (*Q301*) fires and the reset indicator is removed. The counters are now set to zero and are ready to begin counting. The D to A circuits are powered by a temperature compensated supply to improve signal stability.

#### 4.10 OUTPUT AMPLIFIER CIRCUITS DESCRIPTION

The output amplifier provides the drive necessary for the unit voltage output (see paragraph 4-13) or for the drivers when current output or HI option is selected (see paragraph 4-11 or 4-14 respectively). This circuit provides the zero level and signal span adjustments. The output amplifier is a differential amplifier that consists of IC4 and associated components. IC4 receives the output of IC2 (*IC3*) through signal attenuator R26, R27 (*R14, R25*) that provide about a half-volt signal level at the non-inverting input to IC4. The inverting input also receives the bias zero signal. This bias is generated by the zero circuit consisting of voltage divider R10 through R13 (*R15, R16, R26,*

cuit operate from the +12V and -12V supplies.

The active low-pass filter circuit consists of two operational amplifier stages using integrated circuits IC5-1, IC5-7 (*IC2-1*, *IC2-7*) and IC1, with feedback in each stage arranged to produce a low-pass output characteristics. The signal at the wiper of the SPAN potentiometer is applied through R16 (*R17*) and R37 (*R15*) to the inverting input of IC5-1 (*IC2-1*). The adjustment of this potentiometer determines the maximum DC output, or span, of the unit with the maximum frequency applied at the input. R16 (*R17*), R37 (*R15*), and C4 form a low-pass filter for the signal applied to IC5-2 (*IC2-2*) from the previous stage. C8 (*C17*) and R38 (*R41*) provide a feedback signal that changes in phase with increasing frequency in such a way that the stage exhibits a low-pass characteristic more pronounced than that provided by the filter at the input of the stage. The output from IC5-2 (*IC2-2*) is applied through R36 (*R16*) to the next stage.

IC5-7 (*IC2-7*) is arranged in a manner similar to that of IC5-1 (*IC2-1*). A zero adjust circuit is also included in the IC5-7 (*IC2-7*) stage. The zero adjust circuit is connected across  $\pm 6.5$  volts, regulated by Q3 (*Q9*), Q4 (*Q8*) and derived through R30 (*R34*), R31 (*R39*) from the  $\pm 12$ -volt output of the power supply. The voltage at the wiper of the ZERO potentiometer is adjusted so the unit produces the required minimum DC output with zero signal applied to the input. The combined signals (the signal from IC5-1 (*IC2-1*) and that provided by the ZERO potentiometer) are processed through a low-pass filter, consisting of C6 (*C16*), C7 (*C15*) and R39 (*R40*) to the input of IC5 (*IC2*). Feedback changing in phase with increasing frequency is provided from the power amplifier by C9 (*C19*) or C10 (*C18*) and R40 (*R35*), again resulting in a low-pass characteristic. In addition to creating the desired overall low-pass response, the use of two stages in the filter also completely eliminates any interaction between the SPAN and ZERO controls, since these controls are in separate stages. The positive output from IC5-7 (*IC2-7*) is applied through R43 (*R30*) to the voltage divider for all voltage outputs. These circuits are operated from the  $\pm 12$ -volt supplies.

Inverting amplifier IC1 is used whenever a grounded current output is required of the FDT. In this case resistors R21, R22 (*R36*, *R37*) and IC1 are inserted between IC5-1 (*IC2-1*) and IC5-6 (*IC2-6*) to provide the inversion circuit necessary to develop a negative output at IC5-7 (*IC2-7*). Because the pulses applied to the low-pass filter are of constant duration and occur at the input-frequency rate, the duty-cycle of these pulses is directly proportional to frequency. Passing these pulses through a low-pass filter recovers the DC

component of the pulses, which is also directly proportional to frequency because the pulses are of constant amplitude. Thus, filtering the pulses developed and processed in the manner described results in a signal that drives the power amplifier so its output DC level is proportional to the input frequency.

#### 4.10 DESCRIPTION OF PTC AND TC OPTION CIRCUIT

When a unit is ordered with either the PTC or TC (pressure-temperature or temperature compensation) option, the positive amplitude of the output from the switch is made to vary instead of being held constant by the limiter. This variation in amplitude is accomplished by an additional circuit (labeled PTC OR TC OPTION CIRCUIT in Figure 4-1) that replaces the limiter shown in the same illustration. This circuit produces a signal that causes the positive output from the switch to vary in proportion to  $P/T$  or  $1/T$ , where  $P$  is an analog voltage that represents pressure and  $T$  is the output of RB that represents absolute temperature, respectively. Thus, the resulting signal that the switch applies to the following stage consists of pulses with a frequency equal to that of the signal applied to the input of the unit and having an amplitude proportional to  $P/T$  or  $1/T$ , according to whether the PTC or TC option is used.

When a unit is ordered with either the PTC or TC option, an additional circuit is included on PC1 to perform the function required by the option. This circuit replaces the components that normally establish a fixed upper (positive) limit of the signal from the switch. The following is an explanation of the circuit for the PTC option. With only the TC option present, the circuit on PC1 is slightly different from what it is with the PTC option; these differences will be mentioned at appropriate points in the description.

A signal that is a function of the sensed temperature (called the  $T$  signal or simply  $T$ ) derived from a resistance temperature device (RTD) in series with R28 (*R13*) is applied to pin 2 (the inverting input) of IC4 (*IC3*). Transistor Q2 (*Q5*), driven by pin 6 of IC4 (*IC3*), is an emitter-follower stage with its output fed back to pin 2 of IC4 (*IC3*). The feedback path includes R26 (*R42*) and R27 (*R43*) in parallel. It is known, from the theory of operational amplifiers, that the output of an operational amplifier in the inverting configuration, such as IC4 (*IC3*), is proportional to  $R_f$  divided by  $R_{in}$ . In this specific instance,  $R_f$  is formed by R26 (*R42*) and R27 (*R43*) in parallel, and  $R_{in}$  is formed by R28 (*R13*) in series with the RTD. Input voltage to the amplifier circuit is an analog voltage representing pressure.

R27), ZERO potentiometer and zener diodes CR2, CR3 (CR4, CR5). The voltage divider, zener diode network provide a constant signal across the ZERO potentiometer. A shift in the ZERO potentiometer wiper contact can produce either a positive or a negative signal at the inverting input pin 2. This signal is summed with the positive signal at the non-inverting input pin 3. The resultant output of IC4 at pin 6 is an offset voltage that is directly affected by the position of the ZERO potentiometer.

The inverting input also receives the feedback circuit which includes the SPAN potentiometer. This component selects portions of the feedback loop effectively controlling the gain of the amplifier. Variations in the gain of IC4 result in a variation of the signal output span.

#### 4.11 CURRENT OUTPUT CIRCUIT DESCRIPTION

Output amplifier IC4 provides drive current to power amplifiers Q6, Q7 and Q8 (Q201, Q202, Q203 on PC2). Transistor Q6, Q7 (Q202, Q203) are connected in a Darlington configuration. Transistor Q8 (Q201) is connected in parallel with Q7 (Q202) to generate greater drive to —OUT output terminal. A power source of approximately 38 volts is provided at +OUT. This configuration allows the SHM load between the OUT terminals to be driven directly by the power amplifiers, thereby offering a very low output impedance. Capacitor C6 (C201) filters transients from the load circuit.

#### 4.12 SELECTABLE CURRENT (SC) OUTPUT OPTION

The SC option consists of the additional selectable current resistor R102. All other current output circuits are identical to those described in paragraph 4.11. Normally current from the power source flows through the external load through Q8, Q7 (Q202, Q201) and R17 (R201) to ground. When the SC option is selected, however, R17 (R201) is removed and replaced by R102. Load current now flows through R102 and is thereby limited to the value specified by the resistor.

#### 4.13 VOLTAGE OUTPUT CIRCUIT DESCRIPTION

When a voltage output is selected, transistors Q6, Q7 and Q8 (Q201, Q202, and Q203) are removed and the output of IC4, now a higher gain circuit (gain of 10) provides a low impedance output to the OUT terminals. The load now is between the amplifier output and ground and is in parallel with R17 and R34 (R201 and R209).

#### 4.14 HIGH CURRENT, VOLTAGE OUTPUT (HI) OPTION

This option provides higher current for voltage output by adding a driver stage Q7 (Q202) between output amplifier IC4 and the output terminals. Driver Q7 (Q202) is powered by a 38-volt source providing the drive necessary for higher current capability for voltage output. Capacitor C8 (C14) is used for compensation in amplifier IC4.

## MAINTENANCE

### 5.1 INTRODUCTION AND GENERAL INFORMATION

This section contains information to aid in the maintenance of the unit. This includes disassembly instructions for all mechanical options, as well as general troubleshooting. Precautions and special techniques required to replace components are also described.

### 5.2 DISASSEMBLY

When unit troubleshooting is required, it is first necessary to disassemble the unit. The physical configuration of the unit determines the steps to be followed in disassembly. These are described in the following paragraphs.

#### NOTE

Always identify wires — usually by tagging — before disconnecting existing connections.

#### CAUTION

DISCONNECT INPUT SIGNAL AND REMOVE POWER INPUT BEFORE DISASSEMBLING UNIT.

#### 5.2.1 Disassembly of Standard Unit and Units With AB or CP Options

To disassemble a standard, AB, or CP unit, remove the unit from its installed position. If the mounting bracket is used, separate it from the unit by removing the two countersunk screws at the rear of the unit. After the unit has been removed from its installed position, disassemble the unit as follows to gain access to the circuit board.

- Remove the two front Phillips-head screws at the top of the unit.
- Remove the four Phillips-head screws at the bottom of the unit.
- Slide the front panel (with the circuit board still attached) down and free of the sides of the case. Points on the circuit board may now be reached for troubleshooting. It is

suggested that the case be used as a container for storing the removed hardware.

#### 5.2.2 Disassembly of Unit in NEMA Boxes

Normally electrical connections are made to NEMA boxes through conduits. Units are secured on a mounting plate in the NEMA boxes. The following disassembly instructions apply to the various configurations.

*Disassembly of Units in OT, WT and GP Enclosures.* Use the following procedures to disassemble unit:

- Loosen clamps that hold hinged cover on OT and WT enclosures only, and open enclosure.
- Remove plastic safety cover from unit.
- Tag and disconnect wires from unit.
- Loosen four mounting screws that hold unit into box.
- Disassemble unit as described in paragraph 5.2.1.

*Disassembly of Units in FG Enclosure.* Use the following procedures to disassemble unit:

- Loosen four screws that secure cover on box.
- Open box and inspect gasket for damage. Replace if necessary.
- Remove plastic safety cover from unit.
- Tag and disconnect wires from unit.
- Tag and disconnect ground wire from conduit to mounting post.
- Remove four nuts that secure unit to mounting plate in rear of box.
- Disassemble unit as described in paragraph 5.2.1.



### 5.2.3 Disassembly of Units in PB or PT Enclosures

Use the following procedure to disassemble unit:

- a. Remove unit from terminal block by rocking it slightly while pulling upward.
- b. Remove (2) nuts, screws, washers holding front panel to bottom PC board (two front bottom).
- c. Remove two side screws from front panel.
- d. Remove one (1) countersunk screw from back-bottom of unit in bottom of PC board.

Terminal block and card connector are keyed to eliminate error when the unit is reinstalled.

### 5.2.4 Disassembly of Units in EX Enclosures

Use the following procedure to disassemble unit:

- a. Using a bar wrench, attach to wrench lugs and loosen the housing cover from the base.
- b. Unscrew protective cover to expose unit.
- c. Use procedure of paragraph 5.2.3.

### 5.2.5 Disassembly of PM Units

Use the following procedure to disassemble unit. Refer to Figure 5-1 for parts nomenclature.

- a. Pull out safety cover to expose wiring.
- b. Tag and disconnect wires from terminal strip. If troubleshooting requires access to reverse side of PC board, perform the procedure described in next step.
- c. Remove screws holding cover to frame and lift cover off the case assembly.

#### CAUTION

WIRE SERVICE LOOP IS SUFFICIENT TO ALLOW PC BOARD AND END PLATE ASSEMBLIES TO BE TURNED OVER. ANY EXCESSIVE MOVEMENT OF THIS ASSEMBLY MAY CAUSE WIRING DAMAGE.

- d. Remove two nuts and washers that secure PC board and end plate into frame and carefully lift and slide board and plate towards terminal panel, out of end holder.

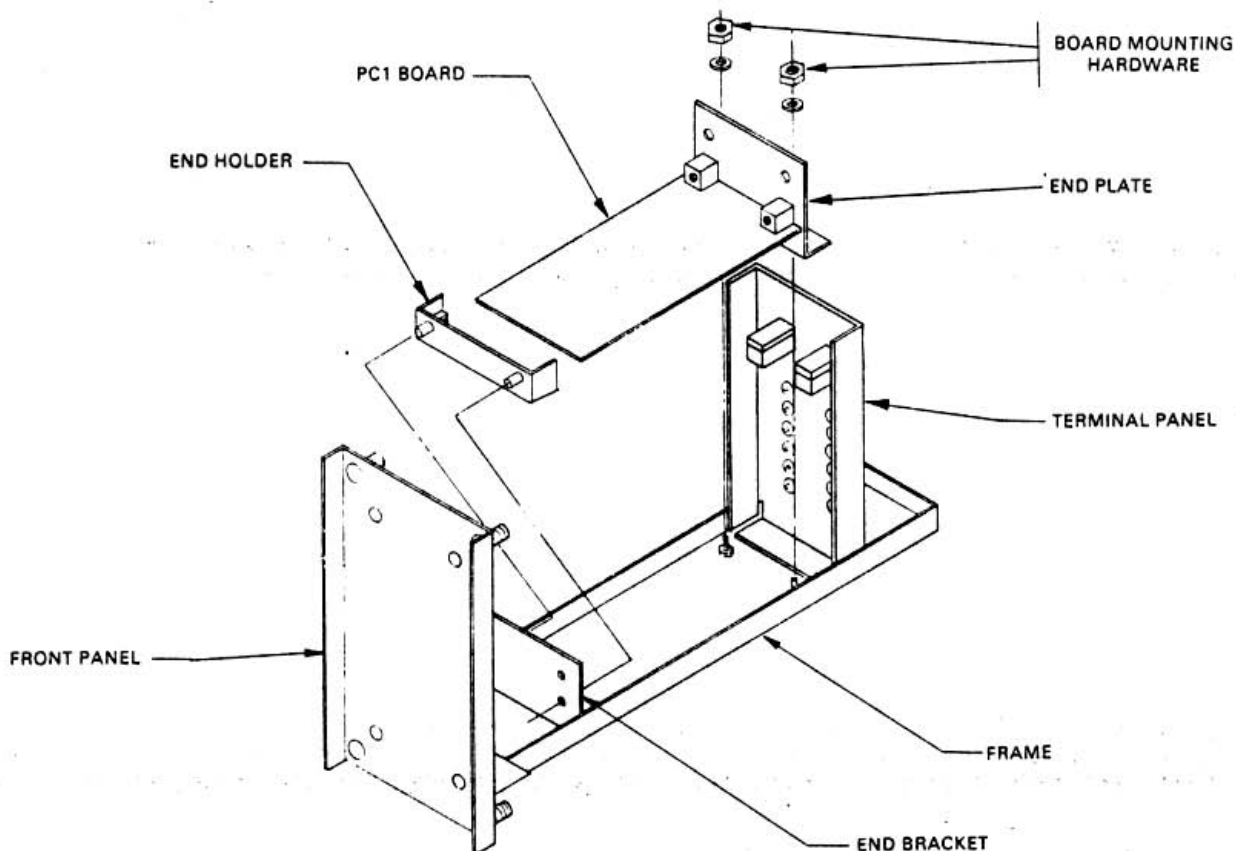

Figure 5-1. Disassembly of PM Units

## 5.2.6 Disassembly of a Plug-In Unit

To remove the cover of a plug-in unit, proceed as follows:

### CAUTION

DO NOT LIFT FRONT OF COVER MORE THAN ¼ INCH. EXCESSIVE FORCE APPLIED TO COVER MAY BREAK REAR RETAINING CLIPS.

- a. Gently spread forward locking feet and lift front of cover.
- b. With the front of the cover raised, slide the cover to the rear to disengage it from the plug-in card.

To test a plug-in unit in the operating position, a circuit board extender card (M.I.I. Part No. 350-513-00 or equivalent) is required. The extender card brings the unit forward so components on circuit board are accessible for troubleshooting.

## 5.2.7 Disassembly of Plug-In Units in Card Racks

Except for SMR, access to units in racks is effected by removing dust cover over plug-in units. Surface Mounted Racks (SMR) do not have a cover over plug-in units since the whole rack may be enclosed into a NEMA box.

## 5.3 TROUBLESHOOTING

The schematic diagrams include flagged numbers (or letters) at various points in the circuit. Table 5-1 gives the voltages and waveforms at these points for specified input-signal conditions. The assembly drawing shows the physical locations of the parts on the circuit board. Bear in mind that the circuit board is protected with a moisture-resistant coating. Therefore, it may be necessary to use a needle-point probe and exert a fair amount of pressure to break through the coating when it is desired to observe the signal or voltage at a specific point. When connecting a probe to a component on the circuit board, exercise care to make sure the probe does not short-circuit to an adjacent component.

In general, troubleshooting is carried out by tracing the signal with an oscilloscope and referring to the schematic diagrams to determine what com-

ponent might be causing an observed abnormal indication. If the original symptom was a complete failure of the unit to operate, the most logical components to suspect are those associated with the power supply in the unit (including any voltage regulators). If the unit was producing an incorrect (but not zero) output, check the outputs from the voltage regulator and, if these are normal, apply a standard input signal and trace the resulting signal through the unit.

## 5.3.1 Plug-In Board Connector Cleaning

Occasionally, modules which have been in service for a long period of time may develop resistive coatings on the gold-plated contacts of the plug-in boards. This coating, if allowed to build up, can cause malfunctions by decreasing the noise margin of a circuit.

There are two types of foreign material coatings which can develop on the gold-plated contacts of a plug-in module. The first type is INORGANIC. This type of contamination results when copper "bleeds" through the gold plating and oxidizes. The second form of contamination involves ORGANIC substances, which usually are a result of careless handling, and are mainly made up of fingerprints, salts, and oils deposited when the plug-in boards are handled by the gold-plated contacts. Contamination by organic substances can be greatly reduced by careful handling of the modules.

Although rack connectors are usually of the self-cleaning type, it may become necessary to clean the module fingers to ensure reliable connection. When module contacts are in need of cleaning, the following procedures are recommended:

### *Removal of Inorganic Contaminants*

- a. Immerse contacts of plug-in board in an ultrasonic bath of deionized water and a detergent, such as Liguinyx, for at least 30 seconds.
- b. Repeat step (a) with pure deionized water only.

### CAUTION

REMOVE WATER IMMEDIATELY FROM CONTACTS. IF THIS IS NOT DONE QUICKLY, DAMAGE TO CONTACTS MAY RESULT.

- c. Remove water by immersing contacts in an ethand or methanol bath to same depth used during the ultrasonic cleaning of step (a). Never wipe or use an abrasive cleaner on the contacts. If wiping is necessary, use K-Dry towels or equivalent.

#### *Removal of Organic Contaminants*

- a. After inorganic contaminants and water have been removed, organic materials may be removed by immersion of contacts in trichloroethane for at least 30 seconds.

#### **CAUTION**

NEVER USE AN ERASER ON THE CONTACTS. THE USE OF ABRASIVE CLEANERS OR ERASERS ON PLUG-IN BOARD CONTACTS IS CONSIDERED A PHYSICAL ABUSE TO THE PLUG-IN UNIT AND MAY VOID THE UNIT WARRANTY.

- b. Let contacts air dry or wipe with a very fine, nonabrasive material such as K-Dry towels or equivalent.

#### **5.3.2 Component Replacement General Information**

Replace all defective components with identical parts. Refer to Section 6 for a list of recommended replacement parts. The last row of numbers in the parts list is the number of spares recommended to be kept on hand for that part, per unit, for up to ten units of the same type. For more than ten units, a spares complement of 10% on the indicated parts should be used.

#### **5.3.3 Component Replacement Techniques**

Most parts used in the unit are quite small and are located in a confined area. Therefore, small hand tools are a necessity when servicing the unit. The following is a summary of the general techniques and precautions that should be observed to prevent damage to components in the unit:

#### **CAUTION**

CMOS INTEGRATED CIRCUITS ARE VERY SUSCEPTIBLE TO STATIC ELECTRICITY. WHEN REPLACING THESE COMPONENTS, DO NOT HANDLE LEADS BEFORE SOLDERING INTO BOARD. ENSURE THAT SOLDERING IRON IS

**GROUNDING. SOLDER INTEGRATED CIRCUITS LEAD V (POWER INPUT) BEFORE SOLDERING G (GROUND CONNECTION).**

**FAILURE TO TAKE THESE PRECAUTIONS WILL DAMAGE COMPONENTS.**

- a. Use a transformer-operated low-voltage soldering iron with a grounded tip and rated at not more than 50 watts. A temperature-controlled tip is desirable.
- b. Use extreme care when unsoldering the leads to any component. Do not keep the soldering iron on a point for more than a few seconds at a time. Use a suction-type solder-removing tool (solder sucker) as an aid in unsoldering transistors and integrated circuits. The protective coating on the unit may be removed with trichloroethane or equivalent. Be sure adequate ventilation is provided when using this or any other chemical.

#### **NOTE**

Unused connections on integrated circuits are left unsoldered to aid in removal. Refer to the assembly drawing for more complete information.

- c. Do not excessively bend or twist the leads of small components; they break easily.
- d. Before removing a component, observe the lead dress. Be sure that the lead dress of the replacement is the same as that of the original.
- e. Remove all flux from soldered joints with trichloroethane or equivalent.

#### **NOTE**

Units that were calibrated at the factory to customer's specifications have protective caps over the SPAN and ZERO potentiometers. These caps must be removed so the unit can be recalibrated. LIFT, DO NOT TWIST, the caps off, using a screwdriver tip as a prying tool. Snap the caps back in place, WITHOUT TWISTING, when recalibration has been completed.

g. Check that all leads are clear of the board edge before reinstalling the board into its

case.

h. When reinstalling the unit onto the mounting bracket, be sure to use the same screws (or screws of the same size) as the ones removed. Longer screws will damage the unit.

**TABLE 5-1. WAVE FORMS AND VOLTAGES .**

TEST POINT	WAVE FORM AND SIGNAL LEVELS
1	-0.7 VDC
2	CURRENT INPUT = 0.2-1 VDC 1-5V = 1-5 VDC 0-5V = 0-5 VDC 0-10V = 0-10 VDC
3	CURRENT INPUT & 1-5V = 1.07-5.07 VDC 0-5V & 0-10V INPUT = 0.07-5.07 VDC
4	STD (SAMPLE MODE) AND TR OPTION = INPUT > OUTPUT = +12 VDC INPUT < OUTPUT = 0 VDC PP OPTION = INPUT > OUTPUT = +12 VDC INPUT < OUTPUT = 0 VDC
5	SAME AS TP 6
6	RANGE OF VOLTAGE SAME AS TP 3 HOWEVER TP 6 IS PROPORTIONAL TO OUTPUT
7	CURRENT INPUT AND 1-5V = 0.1-0.5 VDC 0-5V and 0-10V = 0-0.5 VDC
8	CURRENT OUTPUT AND 1-5V OUTPUT AND -HI OPTION = 0.2-1 VDC 0-5V and 0-10V OUTPUT = 0-1 VDC
9	NORMALLY 0 VDC +12 VDC IF COUNTER COUNTS TOO HIGH (MSB)
10	TEMP. COMP 12.4 VDC
11	+12 VDC
12	-12 VDC
13	+35 VDC
301 401 501	
302 402 502	
303 403 503	

## PARTS LISTS

### 6.1 GENERAL

This section consists of a computer print-out table that provides parts identification information for the unit. Wiring lists have been provided in this section as an aid to the maintenance personnel.

Parts information is grouped according to the number of assemblies. If the unit contains two PC boards, the table will be divided into two major sections: one section will contain information related to PC1 and the other section will list PC2 components information. Each major section in the table contains a complete parts list headed LIST OF MATERIALS specifying which PC board it is describing. This list is usually found at the end of the section. The list of materials consists of the following headings:

*ITEM:* A reference numeral used for data processing and not used by maintenance personnel.

*NAME:* Gives the nomenclature of the part.

*DESCRIPTION:* Identifies the component by manufacturer's part number, usually followed by component's parameters or value.

*REF:* Lists the reference designation for the component, referred to in Section 4, on the schematic and assembly drawings.

*PART NUMBER:* This column specifies the Moore Industries assigned part number. This is the part identification required when ordering parts from Moore Industries.

*SPARE:* The numeral in this column specifies the recommended number of component spares per unit type that should be kept on hand by maintenance personnel.

### 6.2 GLOSSARY OF ABBREVIATIONS

C	Capacitor	R	Resistor
CR	Diode — Zener included	T	Transformer
HW	Special hardware	IC	Integrated circuit
J	Connecting buss wire	Q	Transistor
L	Inductor	LED	Light emitting diode
LBL	Label	TB	Terminal block
PC	Printed circuit board	VS	Voltage regulating varistor

REV	DESCRIPTION	DATE	BY	APP'D
1	REVISED	11/11/77	WV	
2	REVISED	11/11/77	WV	
3	REVISED	11/11/77	WV	
4	REVISED	11/11/77	WV	
5	REVISED	11/11/77	WV	

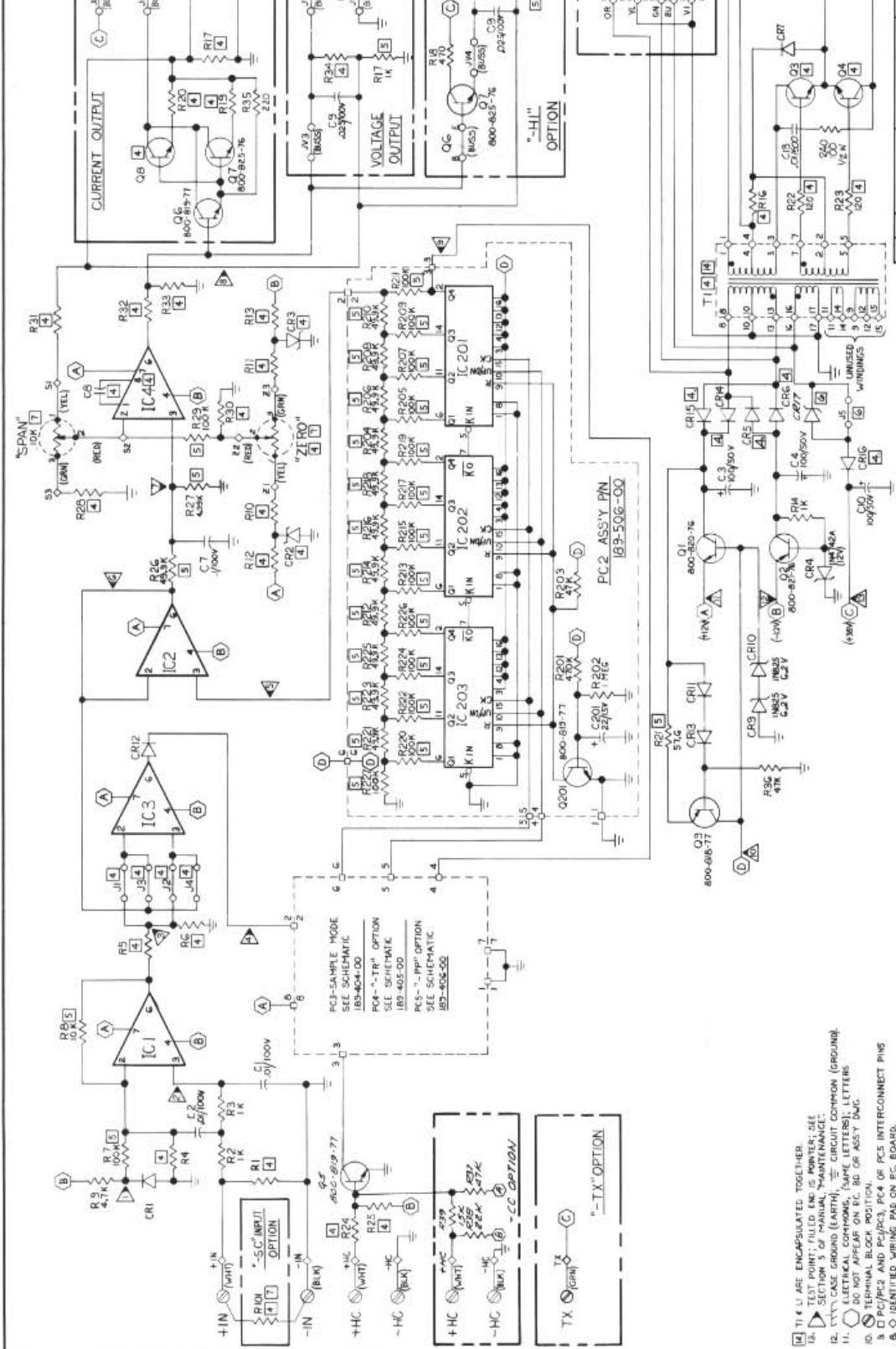

REV	DESCRIPTION	DATE	BY	APP'D
1	REVISED	11/11/77	WV	
2	REVISED	11/11/77	WV	
3	REVISED	11/11/77	WV	
4	REVISED	11/11/77	WV	
5	REVISED	11/11/77	WV	

**PC3-SAMPLE MODE**  
 SEE SCHEMATIC  
 IBS-404-00

**PC4-"-TX" OPTION**  
 SEE SCHEMATIC  
 IBS-405-00

**PC5-"-PPI" OPTION**  
 SEE SCHEMATIC  
 IBS-406-00

**PC2-ASSY P/N**  
 IBS-506-00

**AC POWER OPTION**

**MANUFACTURER**  
 BOBIE INDUSTRIES, INC.  
 VAN NUYS, CALIF.

**5TD SCHEMATIC (PC1PC2)**  
**DIGITAL SHM**

**REV SCALE DRAWING**  
 DATE: 11/11/77

**189-402-00**

1. 1 & 4 U ARE ENCAPSULATED TOGETHER.
  2. TEST POINT; FILLED INK IS POWER; SEE SECTION 5 OF MANUAL, MAINTENANCE.
  3. POTENTIOMETERS INCREASE C.W. FROM 1 TO 3.
  4. SEE LIST OF MATERIALS FOR PART NO., VALUE, AND/OR USAGE.
  5. VSI BLOOMERS V500, EXTERNALLY MTD. FOR "-RT" OPTION.
  6. SEE LIST OF MATERIALS FOR PART NO., VALUE, AND/OR USAGE.
  7. IC1, IC2, ARE U.L.I. P/N 800-857-01 IS P/N 800-857-31; IC3, IC4, ARE U.L.I. P/N 800-857-02 IS P/N 800-857-32; IC5, IC6, ARE U.L.I. P/N 800-857-03 IS P/N 800-857-33.
  8. RESISTORS ARE 1/4 W. CARB. COFF. ±10%.
  9. RESISTANCE IN OHMS; CAPACITANCE IN MICROFARADS.
- NOTE: UNLESS OTHERWISE SPECIFIED



REV.	DESCRIPTION	DATE	BY	APPRV.
------	-------------	------	----	--------

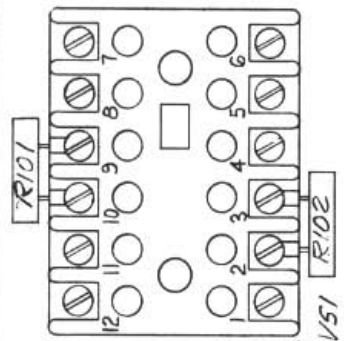
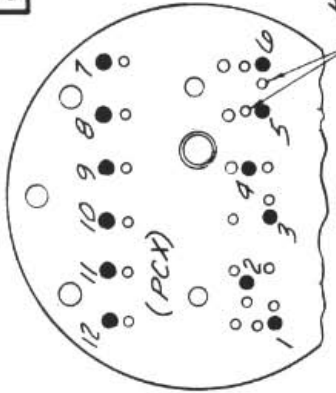

HOLES FOR MOUNTING VSI  
"SR" CASE

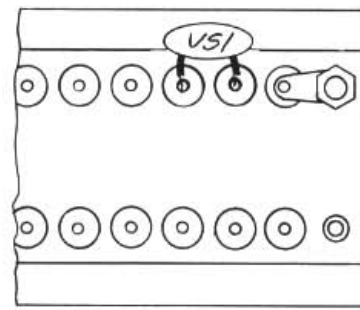

VSI  
(SLEEVE LEADS)

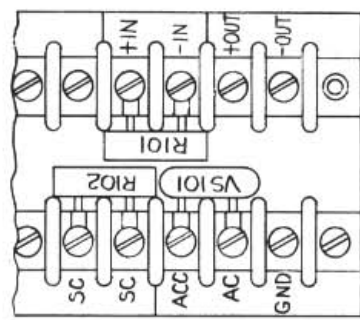

VSI01, R101, R102

"SP" "CH" OR "VT" CASE

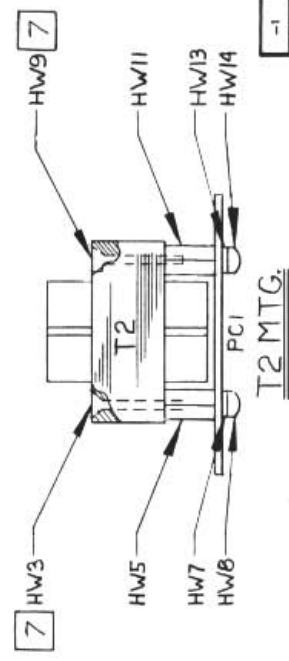
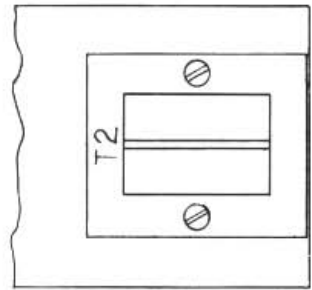

T2 MTG.

ITEM NO.	PART NUMBER	PART NAME	MANUFACTURER	REFERENCE DESIGNATION
1	12-674	P.C. BD. ASS'Y STANDARD DIGITAL	MOORE INDUSTRIES INC. VAN NUYS • CALIF.	189-502-00 H SH. 2 OF 2
TOLERANCES UNLESS NOTED:		SCALE 1/1		
X	±.1	DO NOT SCALE DRAWING		
XX	±.03	JOB NO. 189		
XXX	±.010	SHM PCI		
ANGLES: ±30		PC. BD. ASS'Y STANDARD DIGITAL		
FINISH		DO NOT SCALE DRAWING		
DRAWN: T. HART		SCALE 1/1		
CHECK: R. Kelly		JOB NO. 189		
PROJ. ENGR. M. S. ...		SHM PCI		
CUST.		189-502-00 H		
NEXT ASSEMBLY		SH. 2 OF 2		

NOTES: UNLESS OTHERWISE SPECIFIED



REV.	DESCRIPTION	DATE	BY	APPROV.
B	ECO 2150	10/25/75	JVN	JRS

**WARNING**

DO NOT TOUCH  
LEADS OF I.C.'S  
WITH FINGERS.

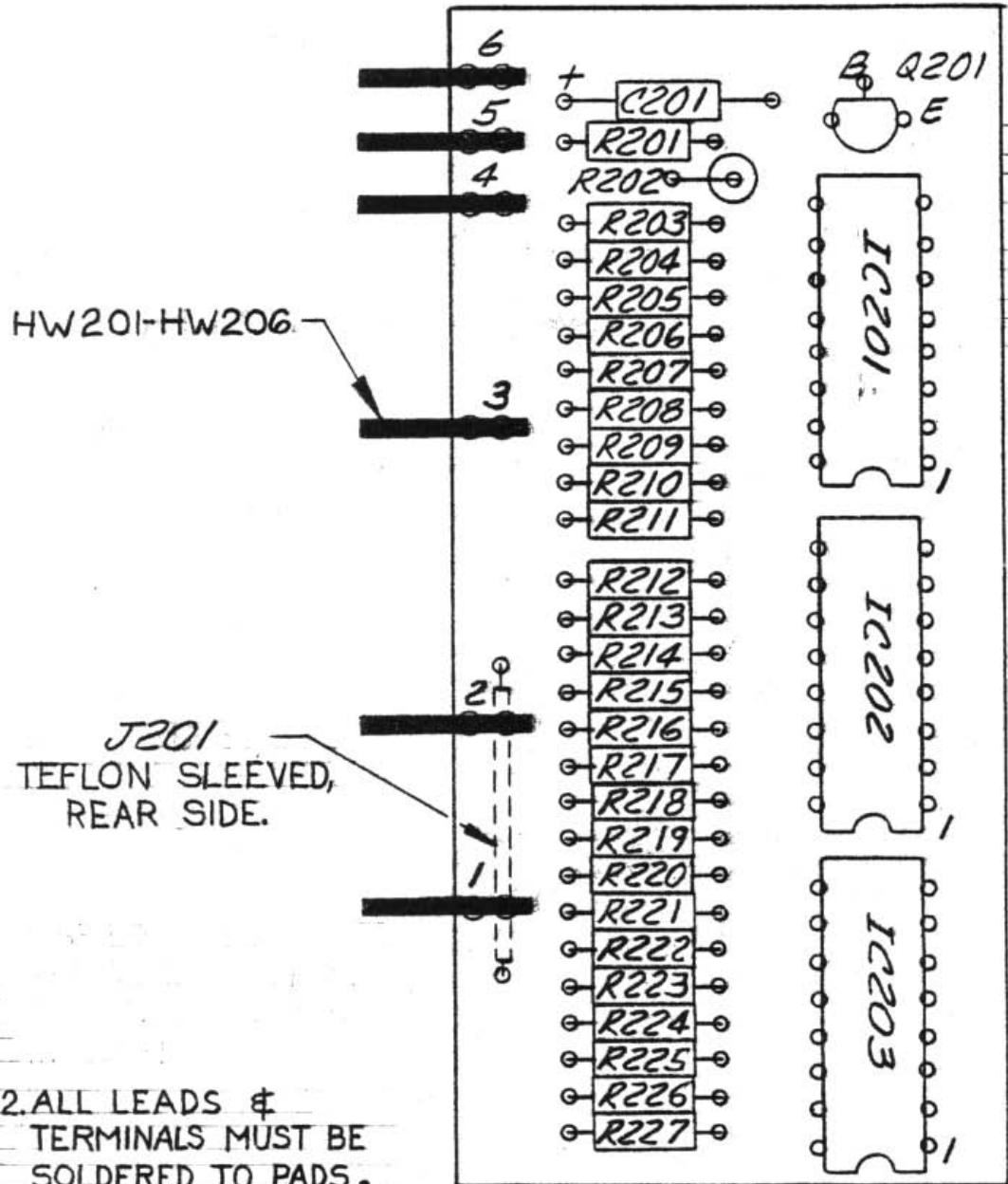

2. ALL LEADS & TERMINALS MUST BE SOLDERED TO PADS.

1. ALL JUMPERS ARE 22AWG BUSS.

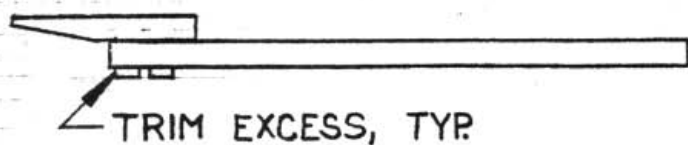

NOTES:

DIMENSIONS ARE IN INCHES UNLESS NOTED OTHERWISE	DRAWN	T. HART	12-4-74	<b>MOORE INDUSTRIES INC.</b> VAN NUYS ■ CA.	P.C. BD. ASS'Y     STD. DIGITAL <b>SHM</b> PC 2
	CHECKED	<i>R. Kelley</i>	2/28/75		
TOLS. UNLESS NOTED: .X = ±.10 .XX = ±.030 .XXX = ±.010 ANGLES = ± 30'	PROJ. ENGR.	<i>71 Reynolds</i>	3/10/75	DWG. NO.	189-506-00
	DO NOT SCALE DRAWING	CUSTOMER		REV.	B
SCALE: 2/1					

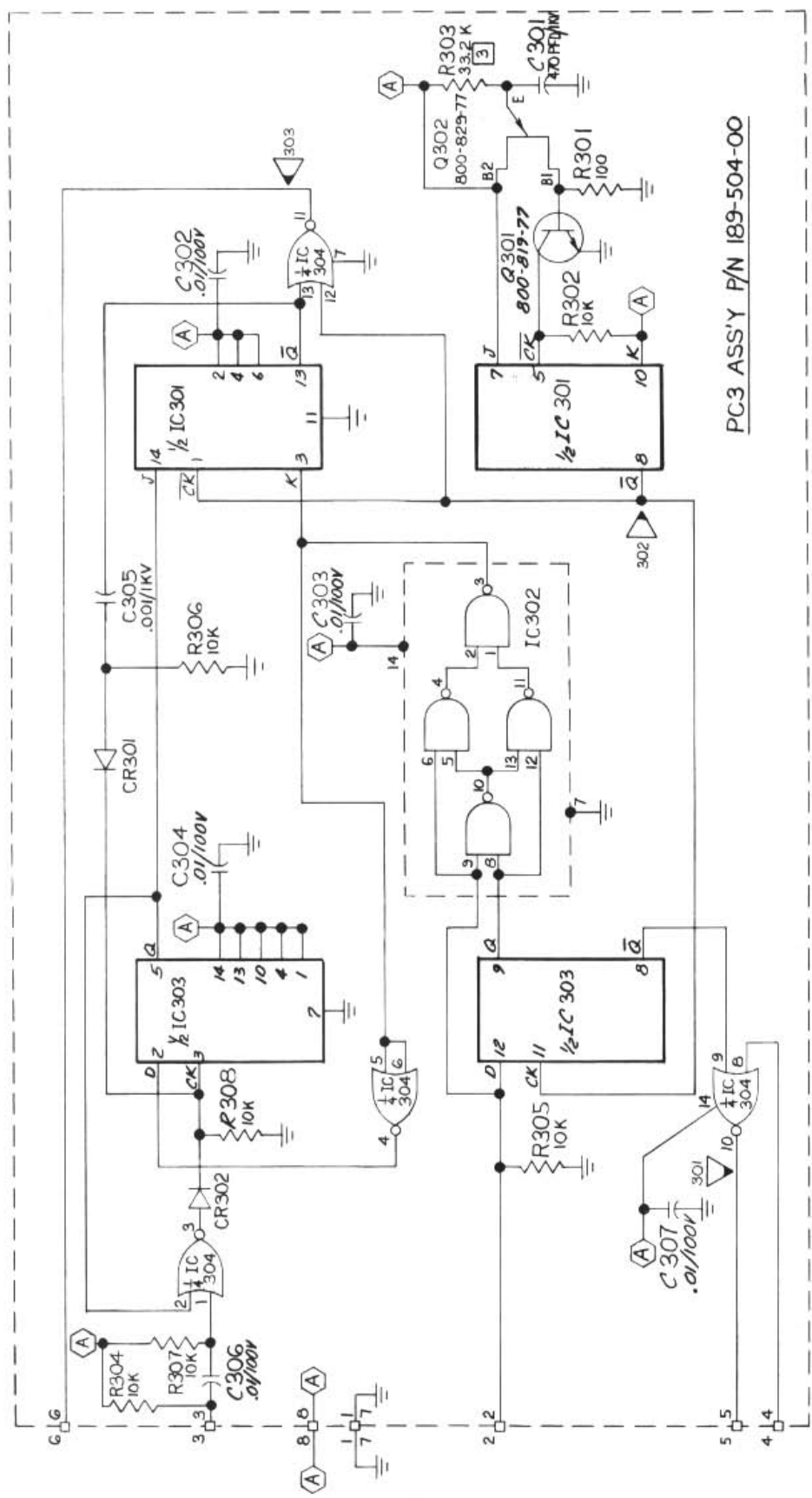

PC3 ASS'Y P/N 189-504-00

- 7. TEST POINT; FILLED END IS POINTER; SEE SECTION 5 OF MANUAL, "MAINTENANCE".
- 8. CIRCUIT COMMON GROUND.
- 9. ELECTRICAL COMMONS, (SAME LETTERS); LETTERS DO NOT APPEAR ON PC BD OR ASSY DWG.
- 10. PC3/PCI INTERCONNECT PINS.
- 11. METAL FILM RESISTOR ±1%.
- 12. IC 301 IS M.I.L. P/N 800-804-32; IC 302 IS 800-808-32; IC 303 IS 800-806-32; IC 304 IS 800-807-32; DIODES ARE 800-4148-11; RESISTORS ARE 1/4 W, CARB. COMP, ±10%.
- 13. RESISTANCE IN OHMS; CAPACITANCE IN MICROFARADS.
- NOTES: UNLESS OTHERWISE SPECIFIED

NO. REV. DATE		ITEM	PART NUMBER	PART NAME	MANUFACTURER	REFERENCE DESIGNATION
-1						
LIST OF MATERIALS						
DRAWN		R. KELLEY		1/14/54		
CHECK		T. HART		2-28-54		
DESIGNED		W. B. WALKER		3/10/54		
FINISH						
NEXT ASSY						
MATERIAL						
SCALE						
FOR NO.		189				
DO NOT SCALE DRAWING						
DIGITAL SHM						
PC3 (STANDARD)						
SAMPLE MODE						
SCHEMATIC						
MOORE INDUSTRIES INC.						
VAN NUYS • CALIF.						
189-404-00B						

REV.	DESCRIPTION	DATE	BY	APPRV
B	ECO 2150	9/24/74	JVN	DR

# WARNING

DO NOT TOUCH LEADS OF INTEGRATED CIRCUITS WITH FINGERS.

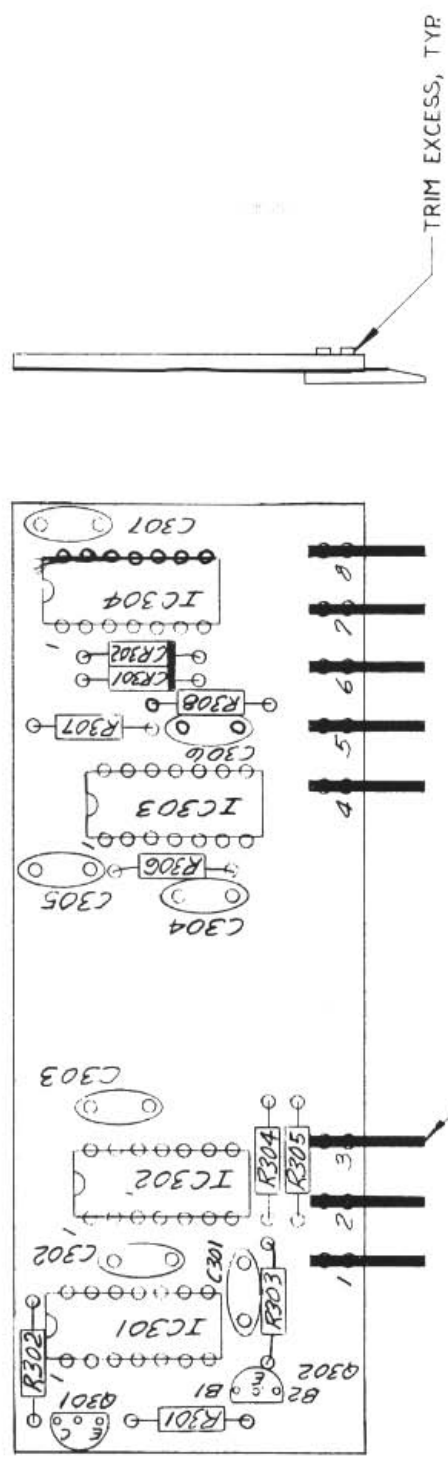

HW 301-HW308

ITEM	PART NUMBER	PART NAME	MANUFACTURER	REFERENCE DESIGNATION
-1				
NO. REQ'D				
LIST OF MATERIALS				
NO.	DESCRIPTION	QTY	UNIT	REMARKS
1	PC. BD. ASS'Y	1	PCB	
2	STD. DIGITAL	1	IC	
3	SHM PC3	1	IC	
4	SAMPLE MODE (STD.)	1	IC	
DO NOT SCALE DRAWING				
SCALE	JOB NO	189		
		189-507-00B		



MOORE INDUSTRIES INC.  
VAN NUYS • CALIF.

1. ALL LEADS & TERMINALS MUST BE SOLDERED TO PADS.

NOTES: UNLESS OTHERWISE SPECIFIED

REV	DESCRIPTION	DATE	BY	APPROV
B	ECO 2150		JWV	

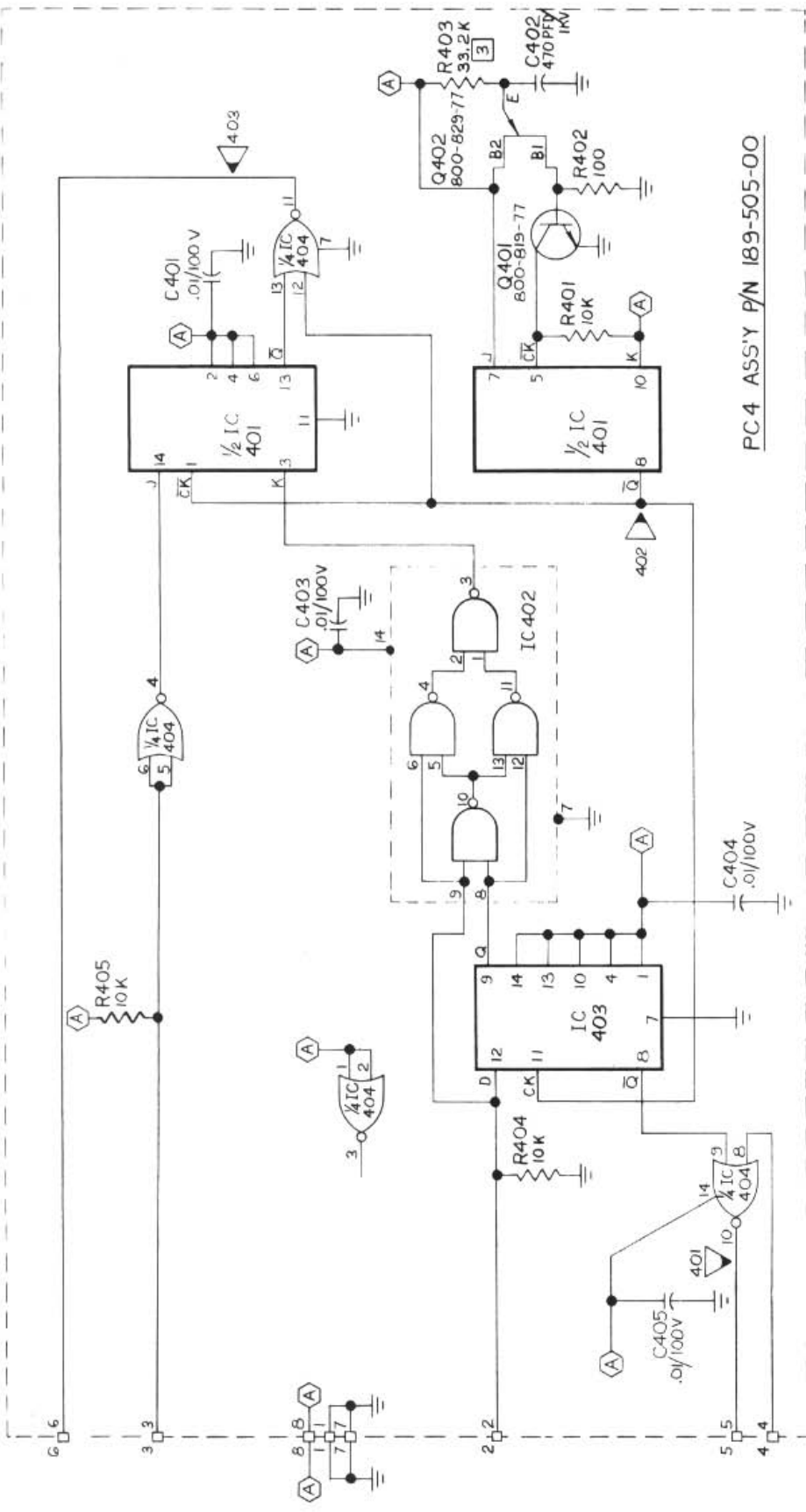

PC4 ASS'Y P/N 189-505-00

- 7. TEST POINT; FILLED END IS POINTER; SEE SECTION 5 OF MANUAL, "MAINTENANCE".
- 8. CIRCUIT COMMON GROUND.
- 9. ELECTRICAL COMMONS, (SAME LETTERS); LETTERS DO NOT APPEAR ON P.C. BOARD ASS'Y DWG.
- 10. PC4/PCI INTERCONNECT PINS.
- 11. METAL FILM RESISTOR, ±1%.
- 12. IC 401 IS M.I.I. P/N 800-804-32; IC 402 IS 800-808-32; IC 403 IS 800-806-32; IC 404 IS 800-807-32; DIODES ARE 800-4148-11; RESISTORS ARE 1/4 W, CARB. COMP, ±10%.
- 13. RESISTANCE IN OHMS; CAPACITANCE IN MICROFARADS.

NOTES: UNLESS OTHERWISE SPECIFIED

-1 REV		ITEM	PART NUMBER	PART NAME	LIST OF MATERIALS	MANUFACTURER	REFERENCE DESIGNATION
800					T. HART 11/14/74		
801					DRAWN		
802					CHECK		
803					PROJ		
804					FINISH		
805					CUST		
806							
807							
808							
809							
810							
811							
812							
813							
814							
815							
816							
817							
818							
819							
820							
821							
822							
823							
824							
825							
826							
827							
828							
829							
830							
831							
832							
833							
834							
835							
836							
837							
838							
839							
840							
841							
842							
843							
844							
845							
846							
847							
848							
849							
850							
851							
852							
853							
854							
855							
856							
857							
858							
859							
860							
861							
862							
863							
864							
865							
866							
867							
868							
869							
870							
871							
872							
873							
874							
875							
876							
877							
878							
879							
880							
881							
882							
883							
884							
885							
886							
887							
888							
889							
890							
891							
892							
893							
894							
895							
896							
897							
898							
899							
900							

SCHEMATIC  
"- TR" OPTION  
PC4  
DIGITAL  
**SHM**  
DO NOT SCALE DRAWING  
JOB NO. 189

MOORE  
INDUSTRIES INC.  
VAN NUYS • CALIF.  
189-405-00B

# WARNING

DO NOT TOUCH LEADS OF INTEGRATED CIRCUITS WITH FINGERS.

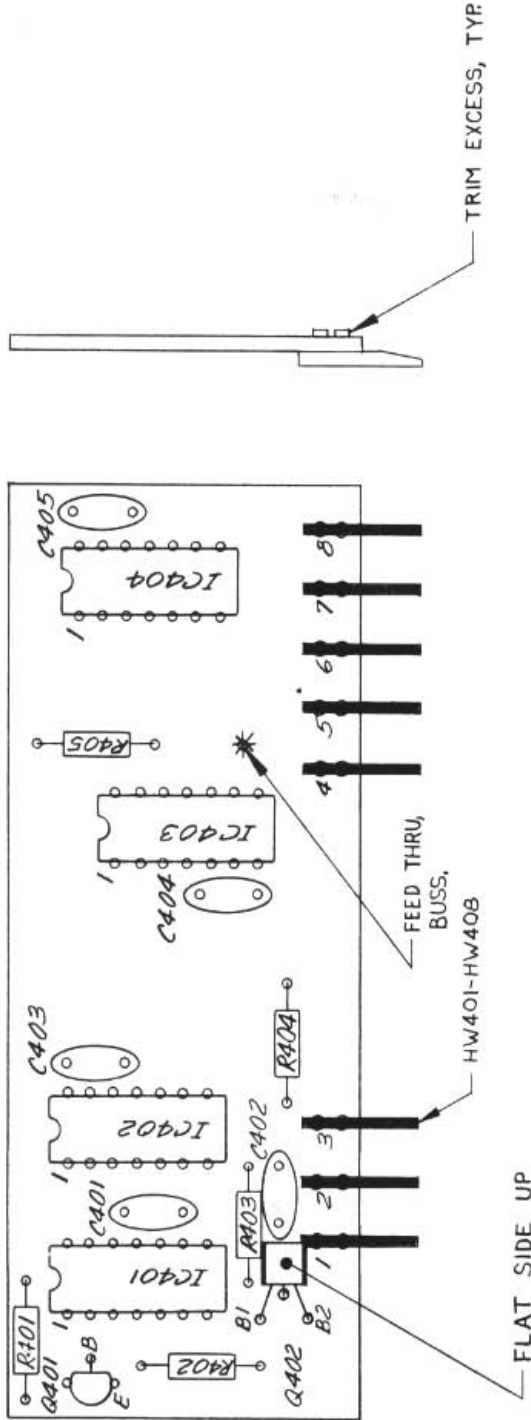

REV.	DESCRIPTION	DATE	BY
B	ECO 2150	10/15/74	JVN

ITEM NO. REQ'D		PART NUMBER		PART NAME		MANUFACTURER		REFERENCE DESIGNATION	
-1				LIST OF MATERIALS					
X		X		T HART		P.C. BD. ASS'Y		MOORE	
XX		XX		CHECK		STD. DIGITAL		INDUSTRIES INC.	
X		X		PROJ. ENGR.		SHM PC4		VAN NUYS • CALIF.	
X		X		CUSTR.		"-TR" OPTION		189-508-00B	
X		X		FINISH		DO NOT SCALE DRAWING		SCALE 2/1	
X		X		NEXT ASSEMBLY		JOB NO. 189			
X		X		DASH NO.					

ALL LEADS & TERMINALS MUST BE SOLDERED TO PADS.

NOTES: UNLESS OTHERWISE SPECIFIED

REV	DESCRIPTION	DATE	BY	APP'D
R	ECO 2150	10/1/74	JWV	

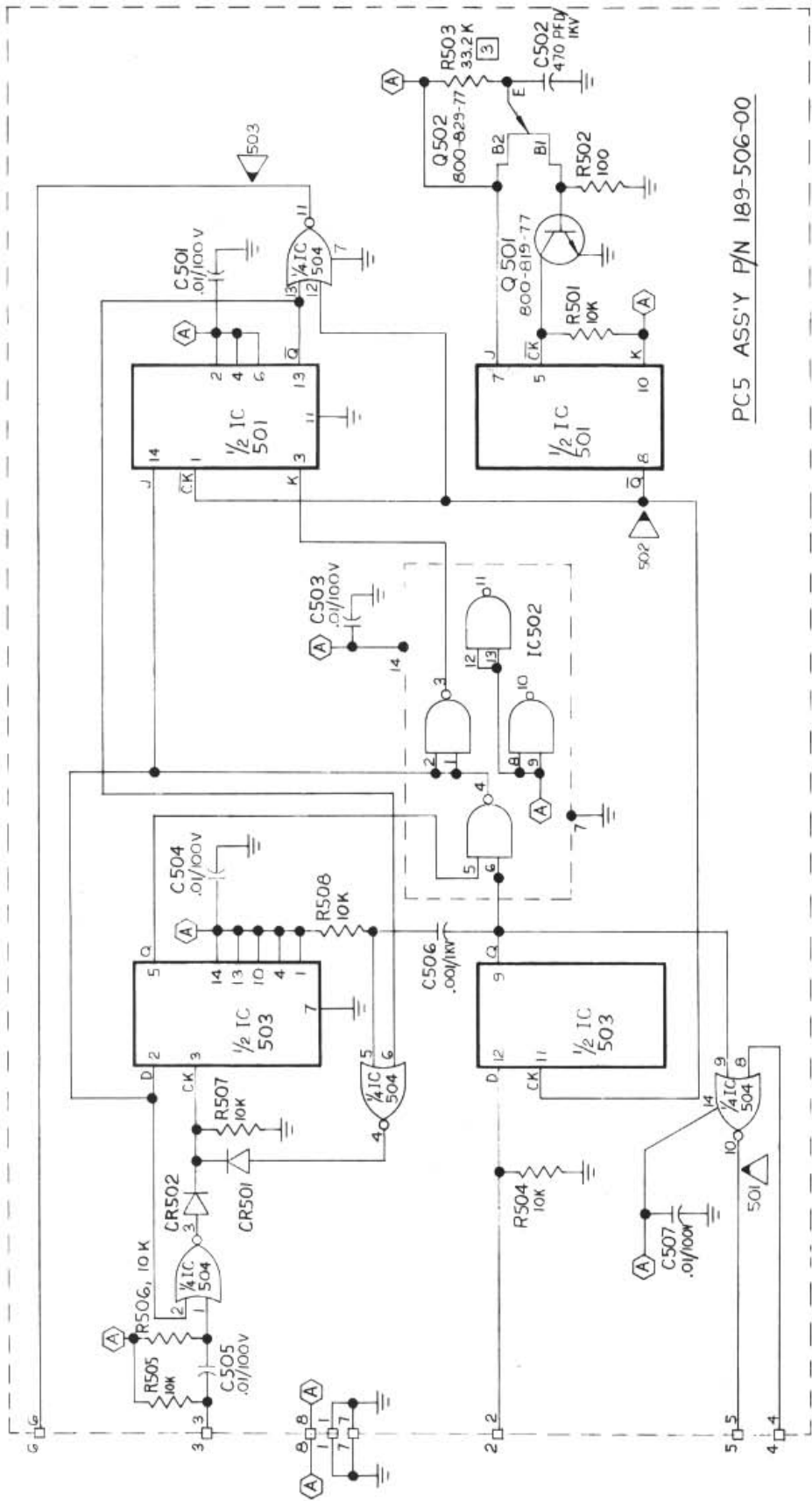

PC5 ASS'Y P/N 189-506-00

- 7. TEST POINT; FILLED END IS POINTER; SEE SECTION 5 OF MANUAL, "MAINTENANCE".
  - 8. CIRCUIT COMMON GROUND.
  - 9. ELECTRICAL COMMONS, (SAME LETTERS); LETTERS DO NOT APPEAR ON PC. BD. OR ASS'Y DWG.
  - 10. PC5/PCI INTERCONNECT PINS.
  - 11. METAL FILM RESISTOR, ±1%.
  - 12. IC 501 IS M.I.I. P/N 800-804-32; IC 502 IS 800-808-32; IC 503 IS 800-806-32; IC 504 IS 800-807-32; DIODES ARE 800-4148-11; RESISTORS ARE ¼ W, CARB. COMP, ±10%.
  - 13. RESISTANCE IN OHMS; CAPACITANCE IN MICROFARADS.
- NOTES: UNLESS OTHERWISE SPECIFIED

ITEM NO.	PART NUMBER	PART NAME	MANUFACTURER	REFERENCE DESIGNATION
1				
2				
3				
4				
5				
6				
7				
8				
9				
10				
11				
12				
13				
14				
15				
16				
17				
18				
19				
20				
21				
22				
23				
24				
25				
26				
27				
28				
29				
30				
31				
32				
33				
34				
35				
36				
37				
38				
39				
40				
41				
42				
43				
44				
45				
46				
47				
48				
49				
50				
51				
52				
53				
54				
55				
56				
57				
58				
59				
60				
61				
62				
63				
64				
65				
66				
67				
68				
69				
70				
71				
72				
73				
74				
75				
76				
77				
78				
79				
80				
81				
82				
83				
84				
85				
86				
87				
88				
89				
90				
91				
92				
93				
94				
95				
96				
97				
98				
99				
100				

MOORE INDUSTRIES INC.  
VAN NUYS • CALIF.

SCHEMATIC  
"-PP" OPTION  
PC5  
DIGITAL  
**SHM**  
DO NOT SCALE DRAWING  
SCALE FOR P/N 189

189-406-00B

# WARNING

DO NOT TOUCH LEADS OF INTEGRATED CIRCUITS WITH FINGERS

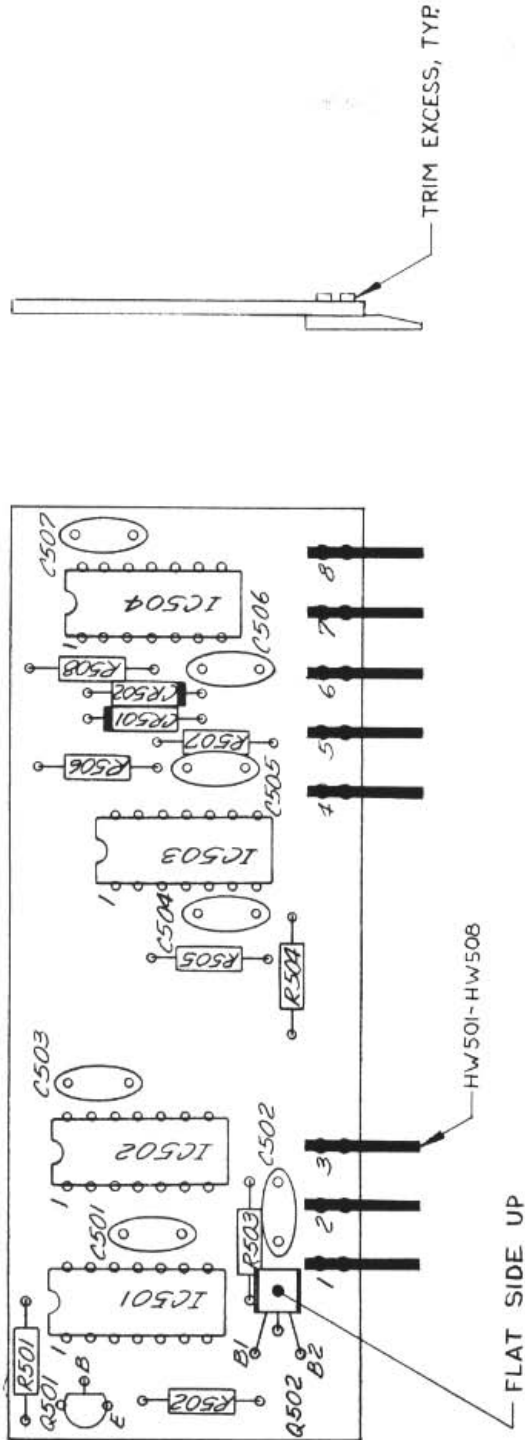

REV.	DESCRIPTION	DATE	BY	APPRV
B	ECO 2150	10/21/76	T.H.	902-

ITEM NO.	PART NUMBER	PART NAME	MANUFACTURER	REFERENCE DESIGNATION
-1				
LIST OF MATERIALS				
NO. REQ'D		T. HART		P.C. BD. ASS'Y
		2-374		STD. DIGITAL
		Drawn	R. P. Boy	<b>SHM</b> PC5
		Check	1/23/75	"-PP" OPTION
		Proj. Engr.	M. G. D.	
		Finish		
		Angles: ±30		
		Tolerances: ±.1, ±.03, ±.010		
		Next Assembly		
		Dash No.		
		Customer		
		Scale	2/1	189-509-00B
		Job No.	189	



MOORE INDUSTRIES INC.  
VAN NUYS • CALIF.

189-509-00B

1. ALL LEADS & TERMINALS MUST BE SOLDERED TO PADS.

NOTES: UNLESS OTHERWISE SPECIFIED

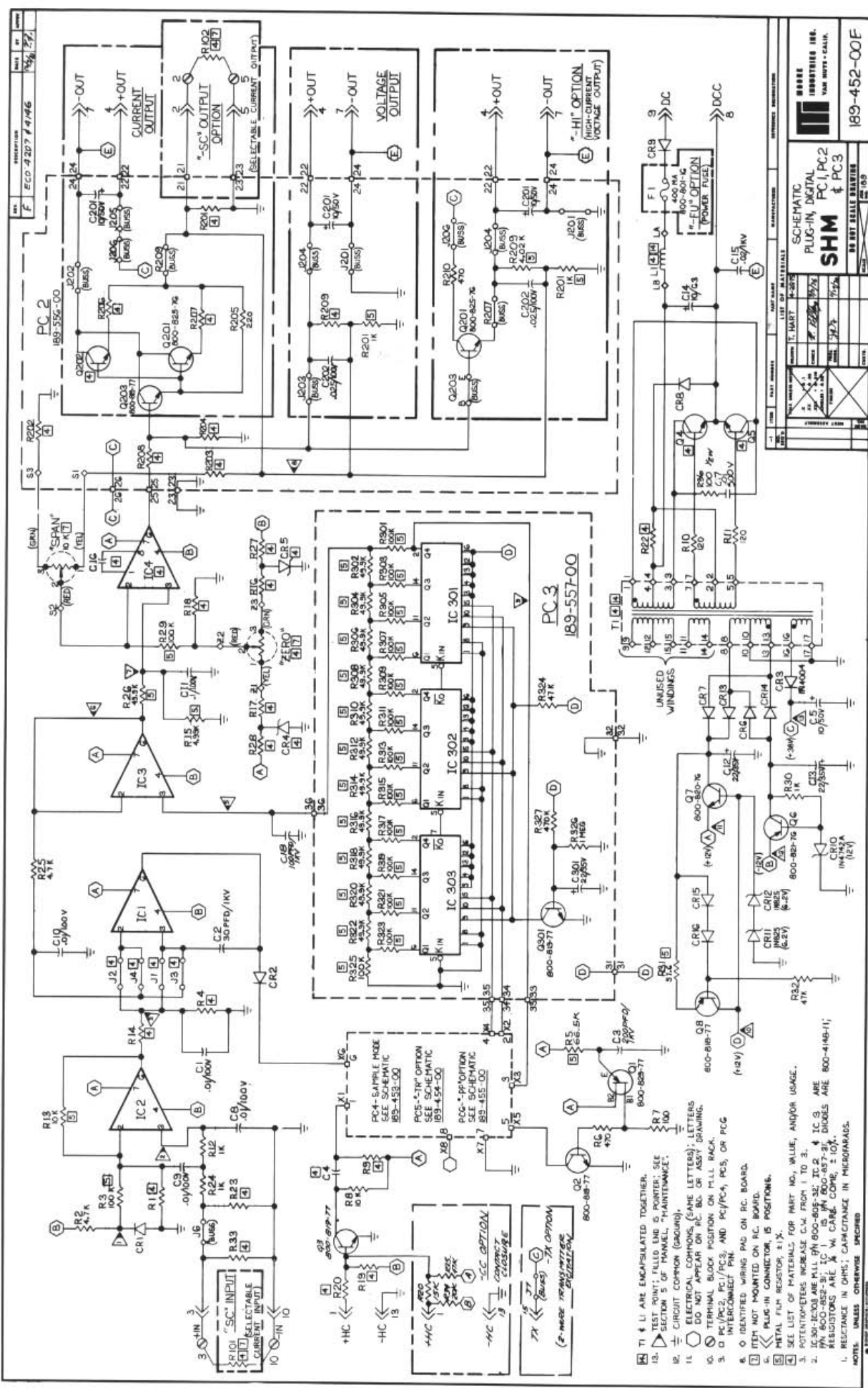

REV. 1  
 F ECG-4207 1/1/66  
 SHEET NO. 1/1

SHM  
 SCHEMATIC  
 PLUG-IN, DIGITAL  
 PC-1, PC-2  
 & PC-3  
 BY THE BELL SYSTEM  
 189-452-00F

- 1. REACTANCE IN OHMS; CAPACITANCE IN MICROFARADS.
- 2. IC 800-852-2; IC 1 IS IN 800-857-2; DIODES ARE 800-4148-11;
- 3. POTENTIOMETERS INCREASE C.W. FROM 1 TO 2.
- 4. IC 800-852-2; IC 1 IS IN 800-857-2; DIODES ARE 800-4148-11;
- 5. RESISTORS ARE  $\frac{1}{2}$  W. CARB. CODE,  $\pm 10\%$ .
- 6. IDENTIFIED WIRING PAD ON P.C. BOARD.
- 7. ITEM NOT MOUNTED ON P.C. BOARD.
- 8. INTERCONNECT PIN.
- 9. D P.C./PC-2, PC-1/PC-3, AND PC-1/PC-4, PC-5, OR PC-6
- 10. DO NOT APPEAR ON P.C. BOARD OR ASSY DRAWING.
- 11. ELECTRICAL COMPONENTS (SAME LETTERS); LETTERS DO NOT APPEAR ON P.C. BOARD OR ASSY DRAWING.
- 12. CIRCUIT COMPONENT (GAINING).
- 13. TEST POINT; FILLED END IS PORTER; SEE SECTION 5 OF MANUAL, "MAINTENANCE."
- 14.  $\square$  ARE ENCAPSULATED TOGETHER.
- 15.  $\square$  ARE IDENTIFIED WIRING PADS ON P.C. BOARD.
- 16.  $\square$  ARE IDENTIFIED WIRING PADS ON P.C. BOARD.
- 17.  $\square$  ARE IDENTIFIED WIRING PADS ON P.C. BOARD.
- 18.  $\square$  ARE IDENTIFIED WIRING PADS ON P.C. BOARD.
- 19.  $\square$  ARE IDENTIFIED WIRING PADS ON P.C. BOARD.
- 20.  $\square$  ARE IDENTIFIED WIRING PADS ON P.C. BOARD.
- 21.  $\square$  ARE IDENTIFIED WIRING PADS ON P.C. BOARD.
- 22.  $\square$  ARE IDENTIFIED WIRING PADS ON P.C. BOARD.
- 23.  $\square$  ARE IDENTIFIED WIRING PADS ON P.C. BOARD.
- 24.  $\square$  ARE IDENTIFIED WIRING PADS ON P.C. BOARD.
- 25.  $\square$  ARE IDENTIFIED WIRING PADS ON P.C. BOARD.
- 26.  $\square$  ARE IDENTIFIED WIRING PADS ON P.C. BOARD.
- 27.  $\square$  ARE IDENTIFIED WIRING PADS ON P.C. BOARD.
- 28.  $\square$  ARE IDENTIFIED WIRING PADS ON P.C. BOARD.
- 29.  $\square$  ARE IDENTIFIED WIRING PADS ON P.C. BOARD.
- 30.  $\square$  ARE IDENTIFIED WIRING PADS ON P.C. BOARD.
- 31.  $\square$  ARE IDENTIFIED WIRING PADS ON P.C. BOARD.
- 32.  $\square$  ARE IDENTIFIED WIRING PADS ON P.C. BOARD.
- 33.  $\square$  ARE IDENTIFIED WIRING PADS ON P.C. BOARD.
- 34.  $\square$  ARE IDENTIFIED WIRING PADS ON P.C. BOARD.
- 35.  $\square$  ARE IDENTIFIED WIRING PADS ON P.C. BOARD.
- 36.  $\square$  ARE IDENTIFIED WIRING PADS ON P.C. BOARD.
- 37.  $\square$  ARE IDENTIFIED WIRING PADS ON P.C. BOARD.
- 38.  $\square$  ARE IDENTIFIED WIRING PADS ON P.C. BOARD.
- 39.  $\square$  ARE IDENTIFIED WIRING PADS ON P.C. BOARD.
- 40.  $\square$  ARE IDENTIFIED WIRING PADS ON P.C. BOARD.
- 41.  $\square$  ARE IDENTIFIED WIRING PADS ON P.C. BOARD.
- 42.  $\square$  ARE IDENTIFIED WIRING PADS ON P.C. BOARD.
- 43.  $\square$  ARE IDENTIFIED WIRING PADS ON P.C. BOARD.
- 44.  $\square$  ARE IDENTIFIED WIRING PADS ON P.C. BOARD.
- 45.  $\square$  ARE IDENTIFIED WIRING PADS ON P.C. BOARD.
- 46.  $\square$  ARE IDENTIFIED WIRING PADS ON P.C. BOARD.
- 47.  $\square$  ARE IDENTIFIED WIRING PADS ON P.C. BOARD.
- 48.  $\square$  ARE IDENTIFIED WIRING PADS ON P.C. BOARD.
- 49.  $\square$  ARE IDENTIFIED WIRING PADS ON P.C. BOARD.
- 50.  $\square$  ARE IDENTIFIED WIRING PADS ON P.C. BOARD.
- 51.  $\square$  ARE IDENTIFIED WIRING PADS ON P.C. BOARD.
- 52.  $\square$  ARE IDENTIFIED WIRING PADS ON P.C. BOARD.
- 53.  $\square$  ARE IDENTIFIED WIRING PADS ON P.C. BOARD.
- 54.  $\square$  ARE IDENTIFIED WIRING PADS ON P.C. BOARD.
- 55.  $\square$  ARE IDENTIFIED WIRING PADS ON P.C. BOARD.
- 56.  $\square$  ARE IDENTIFIED WIRING PADS ON P.C. BOARD.
- 57.  $\square$  ARE IDENTIFIED WIRING PADS ON P.C. BOARD.
- 58.  $\square$  ARE IDENTIFIED WIRING PADS ON P.C. BOARD.
- 59.  $\square$  ARE IDENTIFIED WIRING PADS ON P.C. BOARD.
- 60.  $\square$  ARE IDENTIFIED WIRING PADS ON P.C. BOARD.
- 61.  $\square$  ARE IDENTIFIED WIRING PADS ON P.C. BOARD.
- 62.  $\square$  ARE IDENTIFIED WIRING PADS ON P.C. BOARD.
- 63.  $\square$  ARE IDENTIFIED WIRING PADS ON P.C. BOARD.
- 64.  $\square$  ARE IDENTIFIED WIRING PADS ON P.C. BOARD.
- 65.  $\square$  ARE IDENTIFIED WIRING PADS ON P.C. BOARD.
- 66.  $\square$  ARE IDENTIFIED WIRING PADS ON P.C. BOARD.
- 67.  $\square$  ARE IDENTIFIED WIRING PADS ON P.C. BOARD.
- 68.  $\square$  ARE IDENTIFIED WIRING PADS ON P.C. BOARD.
- 69.  $\square$  ARE IDENTIFIED WIRING PADS ON P.C. BOARD.
- 70.  $\square$  ARE IDENTIFIED WIRING PADS ON P.C. BOARD.
- 71.  $\square$  ARE IDENTIFIED WIRING PADS ON P.C. BOARD.
- 72.  $\square$  ARE IDENTIFIED WIRING PADS ON P.C. BOARD.
- 73.  $\square$  ARE IDENTIFIED WIRING PADS ON P.C. BOARD.
- 74.  $\square$  ARE IDENTIFIED WIRING PADS ON P.C. BOARD.
- 75.  $\square$  ARE IDENTIFIED WIRING PADS ON P.C. BOARD.
- 76.  $\square$  ARE IDENTIFIED WIRING PADS ON P.C. BOARD.
- 77.  $\square$  ARE IDENTIFIED WIRING PADS ON P.C. BOARD.
- 78.  $\square$  ARE IDENTIFIED WIRING PADS ON P.C. BOARD.
- 79.  $\square$  ARE IDENTIFIED WIRING PADS ON P.C. BOARD.
- 80.  $\square$  ARE IDENTIFIED WIRING PADS ON P.C. BOARD.
- 81.  $\square$  ARE IDENTIFIED WIRING PADS ON P.C. BOARD.
- 82.  $\square$  ARE IDENTIFIED WIRING PADS ON P.C. BOARD.
- 83.  $\square$  ARE IDENTIFIED WIRING PADS ON P.C. BOARD.
- 84.  $\square$  ARE IDENTIFIED WIRING PADS ON P.C. BOARD.
- 85.  $\square$  ARE IDENTIFIED WIRING PADS ON P.C. BOARD.
- 86.  $\square$  ARE IDENTIFIED WIRING PADS ON P.C. BOARD.
- 87.  $\square$  ARE IDENTIFIED WIRING PADS ON P.C. BOARD.
- 88.  $\square$  ARE IDENTIFIED WIRING PADS ON P.C. BOARD.
- 89.  $\square$  ARE IDENTIFIED WIRING PADS ON P.C. BOARD.
- 90.  $\square$  ARE IDENTIFIED WIRING PADS ON P.C. BOARD.
- 91.  $\square$  ARE IDENTIFIED WIRING PADS ON P.C. BOARD.
- 92.  $\square$  ARE IDENTIFIED WIRING PADS ON P.C. BOARD.
- 93.  $\square$  ARE IDENTIFIED WIRING PADS ON P.C. BOARD.
- 94.  $\square$  ARE IDENTIFIED WIRING PADS ON P.C. BOARD.
- 95.  $\square$  ARE IDENTIFIED WIRING PADS ON P.C. BOARD.
- 96.  $\square$  ARE IDENTIFIED WIRING PADS ON P.C. BOARD.
- 97.  $\square$  ARE IDENTIFIED WIRING PADS ON P.C. BOARD.
- 98.  $\square$  ARE IDENTIFIED WIRING PADS ON P.C. BOARD.
- 99.  $\square$  ARE IDENTIFIED WIRING PADS ON P.C. BOARD.
- 100.  $\square$  ARE IDENTIFIED WIRING PADS ON P.C. BOARD.

REV.	DATE	DESCRIPTION
1	1/1/66	ISSUED
2	1/1/66	ISSUED
3	1/1/66	ISSUED
4	1/1/66	ISSUED
5	1/1/66	ISSUED
6	1/1/66	ISSUED
7	1/1/66	ISSUED
8	1/1/66	ISSUED
9	1/1/66	ISSUED
10	1/1/66	ISSUED

PC-2  
 189-555-00

PC-3  
 189-557-00

PC-4  
 189-558-00

PC-5  
 189-559-00

PC-6  
 189-560-00



REV.	DESCRIPTION	DATE	APPROV.
E	ECO 4207 #4146	12/1/78	C.F.

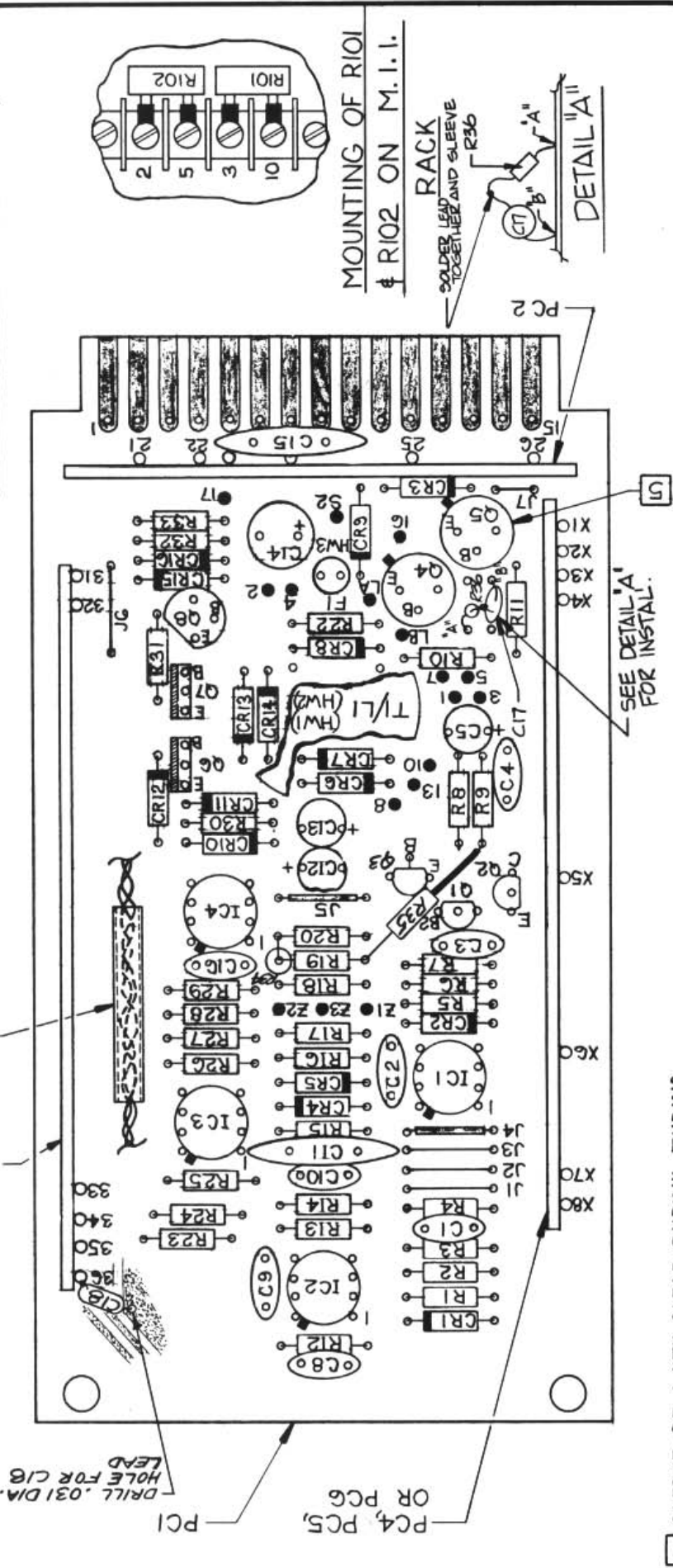

5. SLEEVE Q5 WITH CLEAR SHRINK TUBING.
  4. [Symbol] = METAL SIDE OF Q6 & Q7.
  3. 1-INCH LENGTH OF #9 "TURBOLEX 76" OR EQUIV, CONTACT CEMENT TO PC1, AND DRESS SPAN POT WIRES THRU.
  2. ALL JUMPERS ARE 22 AWG BUSS, TEFLON SLEEVED AS REQUIRED.
  1. ALL LEADS & TERMINALS MUST BE SOLDERED TO PADS.
- NOTES: UNLESS OTHERWISE SPECIFIED

ITEM NO. REG'D	PART NUMBER	PART NAME	MANUFACTURER	REFERENCE DESIGNATION
-1				

  

LIST OF MATERIALS			
DRAWN	T. HART	9-8-75	
CHECK	<i>R. Kelly</i>	12/3/78	
PROJ. ENGR.	<i>J.P.B.</i>	11/27/78	
CUSTR.			

P.C. BOARD ASS'Y PLUG-IN, DIGITAL <b>SHM PC1</b>		 MOORE INDUSTRIES INC. VAN NUYS • CALIF.
DO NOT SCALE DRAWING		
SCALE 2/1	JOB NO. 189	189-552-00F

REV.	DESCRIPTION	DATE	BY	APPRV.
A	INITIAL RELEASE	11/2/78	T.H.	[Signature]

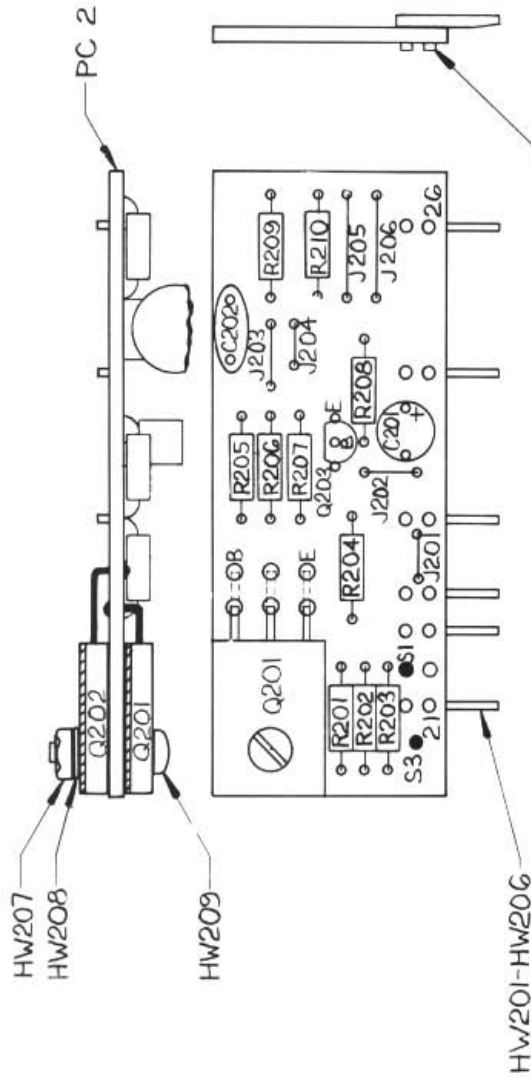

- INDICATES METALIZED SIDE OF Q201 & Q202.
- ALL LEADS & TERMINALS TO BE SOLDERED TO PADS.
- ALL JUMPERS ARE 22 AWG BUSS WIRE, TEFLON SLEEVED AS REQUIRED.

NOTES: UNLESS OTHERWISE SPECIFIED

-1		ITEM	PART NUMBER	PART NAME	MANUFACTURER	REFERENCE DESIGNATION
NO. REQ'D		LIST OF MATERIALS				
		Q201				
		Q202				
		R201				
		R202				
		R203				
		R204				
		R205				
		R206				
		R207				
		R208				
		R209				
		J201				
		J202				
		J203				
		J204				
		S3				
		O2G				
		HW201				
		HW202				
		HW203				
		HW204				
		HW205				
		HW206				
		HW207				
		HW208				
		HW209				
		PC 2				
		TRIM EXCESS, TYP.				
		FINISH				
		ANGLES: ±30				
		±.01				
		±.03				
		±.10				
		±.30				
		±.50				
		±.75				
		±1.00				
		±1.50				
		±2.00				
		±3.00				
		±4.00				
		±5.00				
		±6.00				
		±7.00				
		±8.00				
		±9.00				
		±10.00				
		±12.00				
		±15.00				
		±20.00				
		±25.00				
		±30.00				
		±40.00				
		±50.00				
		±60.00				
		±75.00				
		±90.00				
		±100.00				
		±120.00				
		±150.00				
		±200.00				
		±250.00				
		±300.00				
		±400.00				
		±500.00				
		±600.00				
		±750.00				
		±900.00				
		±1000.00				
		±1200.00				
		±1500.00				
		±2000.00				
		±2500.00				
		±3000.00				
		±4000.00				
		±5000.00				
		±6000.00				
		±7500.00				
		±9000.00				
		±10000.00				
		±12000.00				
		±15000.00				
		±20000.00				
		±25000.00				
		±30000.00				
		±40000.00				
		±50000.00				
		±60000.00				
		±75000.00				
		±90000.00				
		±100000.00				
		±120000.00				
		±150000.00				
		±200000.00				
		±250000.00				
		±300000.00				
		±400000.00				
		±500000.00				
		±600000.00				
		±750000.00				
		±900000.00				
		±1000000.00				
		±1200000.00				
		±1500000.00				
		±2000000.00				
		±2500000.00				
		±3000000.00				
		±4000000.00				
		±5000000.00				
		±6000000.00				
		±7500000.00				
		±9000000.00				
		±10000000.00				
		±12000000.00				
		±15000000.00				
		±20000000.00				
		±25000000.00				
		±30000000.00				
		±40000000.00				
		±50000000.00				
		±60000000.00				
		±75000000.00				
		±90000000.00				
		±100000000.00				
		±120000000.00				
		±150000000.00				
		±200000000.00				
		±250000000.00				
		±300000000.00				
		±400000000.00				
		±500000000.00				
		±600000000.00				
		±750000000.00				
		±900000000.00				
		±1000000000.00				
		±1200000000.00				
		±1500000000.00				
		±2000000000.00				
		±2500000000.00				
		±3000000000.00				
		±4000000000.00				
		±5000000000.00				
		±6000000000.00				
		±7500000000.00				
		±9000000000.00				
		±10000000000.00				
		±12000000000.00				
		±15000000000.00				
		±20000000000.00				
		±25000000000.00				
		±30000000000.00				
		±40000000000.00				
		±50000000000.00				
		±60000000000.00				
		±75000000000.00				
		±90000000000.00				
		±100000000000.00				
		±120000000000.00				
		±150000000000.00				
		±200000000000.00				
		±250000000000.00				
		±300000000000.00				
		±400000000000.00				
		±500000000000.00				
		±600000000000.00				
		±750000000000.00				
		±900000000000.00				
		±1000000000000.00				
		±1200000000000.00				
		±1500000000000.00				
		±2000000000000.00				
		±2500000000000.00				
		±3000000000000.00				
		±4000000000000.00				
		±5000000000000.00				
		±6000000000000.00				
		±7500000000000.00				
		±9000000000000.00				
		±10000000000000.00				
		±12000000000000.00				
		±15000000000000.00				
		±20000000000000.00				
		±25000000000000.00				
		±30000000000000.00				
		±40000000000000.00				
		±50000000000000.00				
		±60000000000000.00				
		±75000000000000.00				
		±90000000000000.00				
		±100000000000000.00				
		±120000000000000.00				
		±150000000000000.00				
		±200000000000000.00				
		±250000000000000.00				
		±300000000000000.00				
		±400000000000000.00				
		±500000000000000.00				
		±600000000000000.00				
		±750000000000000.00				
		±900000000000000.00				
		±1000000000000000.00				
		±1200000000000000.00				
		±1500000000000000.00				
		±2000000000000000.00				
		±2500000000000000.00				
		±3000000000000000.00				
		±4000000000000000.00				
		±5000000000000000.00				
		±6000000000000000.00				
		±7500000000000000.00				
		±9000000000000000.00				
		±10000000000000000.00				
		±12000000000000000.00				
		±15000000000000000.00				
		±20000000000000000.00				

# WARNING

DO NOT TOUCH LEADS  
OF INTEGRATED CIRCUITS  
WITH FINGERS.

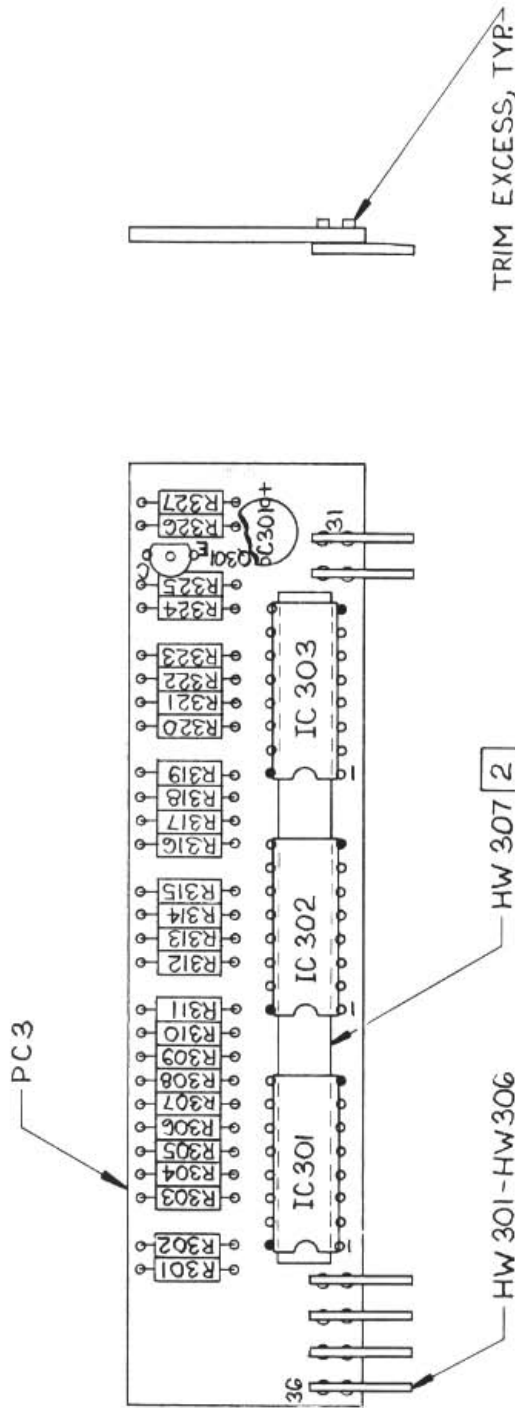

REV.	DESCRIPTION	DATE	BY	APPRV
A	INITIAL RELEASE	10/5/76	T.H.	g.r.s.

ITEM	PART NUMBER	PART NAME	MANUFACTURER	REFERENCE DESIGNATION
-1	NO. REQ'D	LIST OF MATERIALS		
189-552-00	00	T. HART 9-9-75		P.C. BOARD ASSY
		CHECK <i>R. Kelly</i>		PLUG-IN, DIGITAL
		PROJ. ENGR.		<b>SHM PC3</b>
		CUSTR.		MOORE INDUSTRIES INC.
				VAN NUYS • CALIF.
				189-557-00A
				DO NOT SCALE DRAWING
				SCALE 2/1
				JOB NO. 189

2. BEFORE INSTALLING IC'S, INSERT LEADS OF HW307 INTO DARKENED HOLES (•) AND BEND BACK INSULATION ON EDGE OF HW307 WITH NON-METALLIC PROBE TO PROVIDE CLEARANCE BETWEEN INSULATOR & IC PINS.

1. ALL LEADS AND TERMINALS MUST BE SOLDERED TO PADS.

NOTES UNLESS OTHERWISE SPECIFIED

REV	DESCRIPTION	DATE	BY	APPROV
A	INITIAL RELEASE	11/14/64	T.H.	J.P.L.

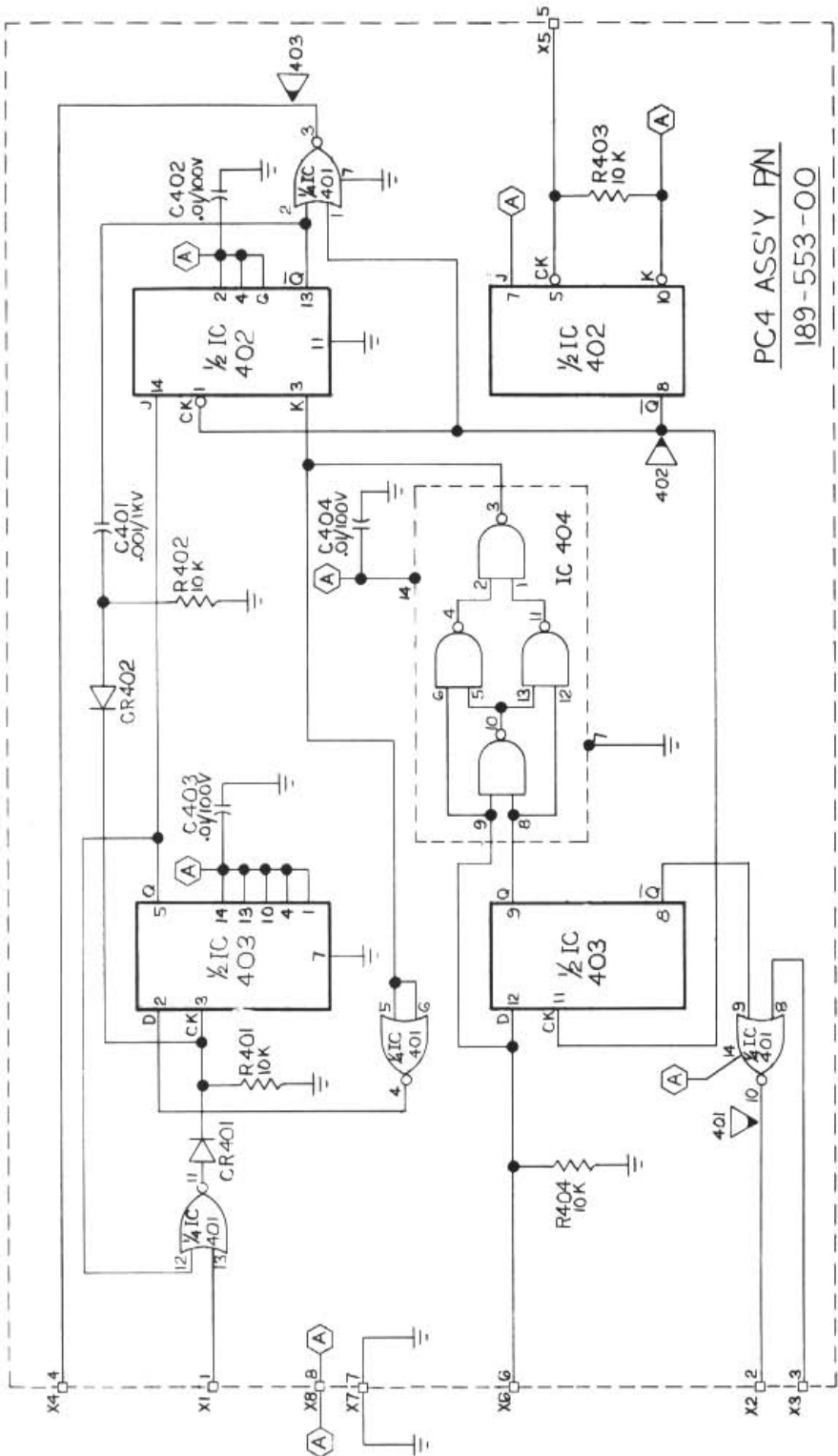

PC-4 ASS'Y P/N  
189-553-00

- 6. TEST POINT; FILLED END IS POINTER; SEE SECTION 5 OF MANUAL, "MAINTENANCE".
- 7. CIRCUI COMMON (GROUND).
- 8. ELECTRICAL COMMONS, (SAME LETTERS); LETTERS DO NOT APPEAR ON PC BOARD OR ASSY DRAWING.
- 9. PC-1/PC-4 INTERCONNECT PIN.
- 10. IC 401 IS M.I.I. P/N 800-807-32; IC 402 IS 800-804-32; IC 403 IS 800-806-32; IC 404 IS 800-808-32; DIODES ARE 800-4148-11; RESISTORS ARE 1/4 W, CARB. COMB, ±10%.
- 11. RESISTANCE IN OHMS; CAPACITANCE IN MICROFARADS.

NOTES: UNLESS OTHERWISE SPECIFIED

-1		ITEM	PART NUMBER	PART NAME	LIST OF MATERIALS	MANUFACTURER	REFERENCE DESIGNATION
-2		ITEM	PART NUMBER	PART NAME	LIST OF MATERIALS	MANUFACTURER	REFERENCE DESIGNATION
-3		ITEM	PART NUMBER	PART NAME	LIST OF MATERIALS	MANUFACTURER	REFERENCE DESIGNATION
-4		ITEM	PART NUMBER	PART NAME	LIST OF MATERIALS	MANUFACTURER	REFERENCE DESIGNATION
-5		ITEM	PART NUMBER	PART NAME	LIST OF MATERIALS	MANUFACTURER	REFERENCE DESIGNATION
-6		ITEM	PART NUMBER	PART NAME	LIST OF MATERIALS	MANUFACTURER	REFERENCE DESIGNATION
-7		ITEM	PART NUMBER	PART NAME	LIST OF MATERIALS	MANUFACTURER	REFERENCE DESIGNATION
-8		ITEM	PART NUMBER	PART NAME	LIST OF MATERIALS	MANUFACTURER	REFERENCE DESIGNATION
-9		ITEM	PART NUMBER	PART NAME	LIST OF MATERIALS	MANUFACTURER	REFERENCE DESIGNATION
-10		ITEM	PART NUMBER	PART NAME	LIST OF MATERIALS	MANUFACTURER	REFERENCE DESIGNATION
-11		ITEM	PART NUMBER	PART NAME	LIST OF MATERIALS	MANUFACTURER	REFERENCE DESIGNATION
-12		ITEM	PART NUMBER	PART NAME	LIST OF MATERIALS	MANUFACTURER	REFERENCE DESIGNATION
-13		ITEM	PART NUMBER	PART NAME	LIST OF MATERIALS	MANUFACTURER	REFERENCE DESIGNATION
-14		ITEM	PART NUMBER	PART NAME	LIST OF MATERIALS	MANUFACTURER	REFERENCE DESIGNATION
-15		ITEM	PART NUMBER	PART NAME	LIST OF MATERIALS	MANUFACTURER	REFERENCE DESIGNATION
-16		ITEM	PART NUMBER	PART NAME	LIST OF MATERIALS	MANUFACTURER	REFERENCE DESIGNATION
-17		ITEM	PART NUMBER	PART NAME	LIST OF MATERIALS	MANUFACTURER	REFERENCE DESIGNATION
-18		ITEM	PART NUMBER	PART NAME	LIST OF MATERIALS	MANUFACTURER	REFERENCE DESIGNATION
-19		ITEM	PART NUMBER	PART NAME	LIST OF MATERIALS	MANUFACTURER	REFERENCE DESIGNATION
-20		ITEM	PART NUMBER	PART NAME	LIST OF MATERIALS	MANUFACTURER	REFERENCE DESIGNATION
-21		ITEM	PART NUMBER	PART NAME	LIST OF MATERIALS	MANUFACTURER	REFERENCE DESIGNATION
-22		ITEM	PART NUMBER	PART NAME	LIST OF MATERIALS	MANUFACTURER	REFERENCE DESIGNATION
-23		ITEM	PART NUMBER	PART NAME	LIST OF MATERIALS	MANUFACTURER	REFERENCE DESIGNATION
-24		ITEM	PART NUMBER	PART NAME	LIST OF MATERIALS	MANUFACTURER	REFERENCE DESIGNATION
-25		ITEM	PART NUMBER	PART NAME	LIST OF MATERIALS	MANUFACTURER	REFERENCE DESIGNATION
-26		ITEM	PART NUMBER	PART NAME	LIST OF MATERIALS	MANUFACTURER	REFERENCE DESIGNATION
-27		ITEM	PART NUMBER	PART NAME	LIST OF MATERIALS	MANUFACTURER	REFERENCE DESIGNATION
-28		ITEM	PART NUMBER	PART NAME	LIST OF MATERIALS	MANUFACTURER	REFERENCE DESIGNATION
-29		ITEM	PART NUMBER	PART NAME	LIST OF MATERIALS	MANUFACTURER	REFERENCE DESIGNATION
-30		ITEM	PART NUMBER	PART NAME	LIST OF MATERIALS	MANUFACTURER	REFERENCE DESIGNATION
-31		ITEM	PART NUMBER	PART NAME	LIST OF MATERIALS	MANUFACTURER	REFERENCE DESIGNATION
-32		ITEM	PART NUMBER	PART NAME	LIST OF MATERIALS	MANUFACTURER	REFERENCE DESIGNATION
-33		ITEM	PART NUMBER	PART NAME	LIST OF MATERIALS	MANUFACTURER	REFERENCE DESIGNATION
-34		ITEM	PART NUMBER	PART NAME	LIST OF MATERIALS	MANUFACTURER	REFERENCE DESIGNATION
-35		ITEM	PART NUMBER	PART NAME	LIST OF MATERIALS	MANUFACTURER	REFERENCE DESIGNATION
-36		ITEM	PART NUMBER	PART NAME	LIST OF MATERIALS	MANUFACTURER	REFERENCE DESIGNATION
-37		ITEM	PART NUMBER	PART NAME	LIST OF MATERIALS	MANUFACTURER	REFERENCE DESIGNATION
-38		ITEM	PART NUMBER	PART NAME	LIST OF MATERIALS	MANUFACTURER	REFERENCE DESIGNATION
-39		ITEM	PART NUMBER	PART NAME	LIST OF MATERIALS	MANUFACTURER	REFERENCE DESIGNATION
-40		ITEM	PART NUMBER	PART NAME	LIST OF MATERIALS	MANUFACTURER	REFERENCE DESIGNATION
-41		ITEM	PART NUMBER	PART NAME	LIST OF MATERIALS	MANUFACTURER	REFERENCE DESIGNATION
-42		ITEM	PART NUMBER	PART NAME	LIST OF MATERIALS	MANUFACTURER	REFERENCE DESIGNATION
-43		ITEM	PART NUMBER	PART NAME	LIST OF MATERIALS	MANUFACTURER	REFERENCE DESIGNATION
-44		ITEM	PART NUMBER	PART NAME	LIST OF MATERIALS	MANUFACTURER	REFERENCE DESIGNATION
-45		ITEM	PART NUMBER	PART NAME	LIST OF MATERIALS	MANUFACTURER	REFERENCE DESIGNATION
-46		ITEM	PART NUMBER	PART NAME	LIST OF MATERIALS	MANUFACTURER	REFERENCE DESIGNATION
-47		ITEM	PART NUMBER	PART NAME	LIST OF MATERIALS	MANUFACTURER	REFERENCE DESIGNATION
-48		ITEM	PART NUMBER	PART NAME	LIST OF MATERIALS	MANUFACTURER	REFERENCE DESIGNATION
-49		ITEM	PART NUMBER	PART NAME	LIST OF MATERIALS	MANUFACTURER	REFERENCE DESIGNATION
-50		ITEM	PART NUMBER	PART NAME	LIST OF MATERIALS	MANUFACTURER	REFERENCE DESIGNATION

MOORE INDUSTRIES INC.  
VAN NUYS • CALIF.

SCHEMATIC  
PLUG-IN, DIGITAL  
**SHM** PC 4  
SAMPLE MODE (STD)

DO NOT SCALE DRAWING  
SCALE: 100%  
JOB NO. 189

189-453-00A

REV.	DESCRIPTION	DATE	BY	APPRV
A	INITIAL RELEASE	11/21/78	T.H.	jlh

**WARNING**  
DO NOT TOUCH LEADS  
OF INTEGRATED CIRCUITS  
WITH FINGERS.

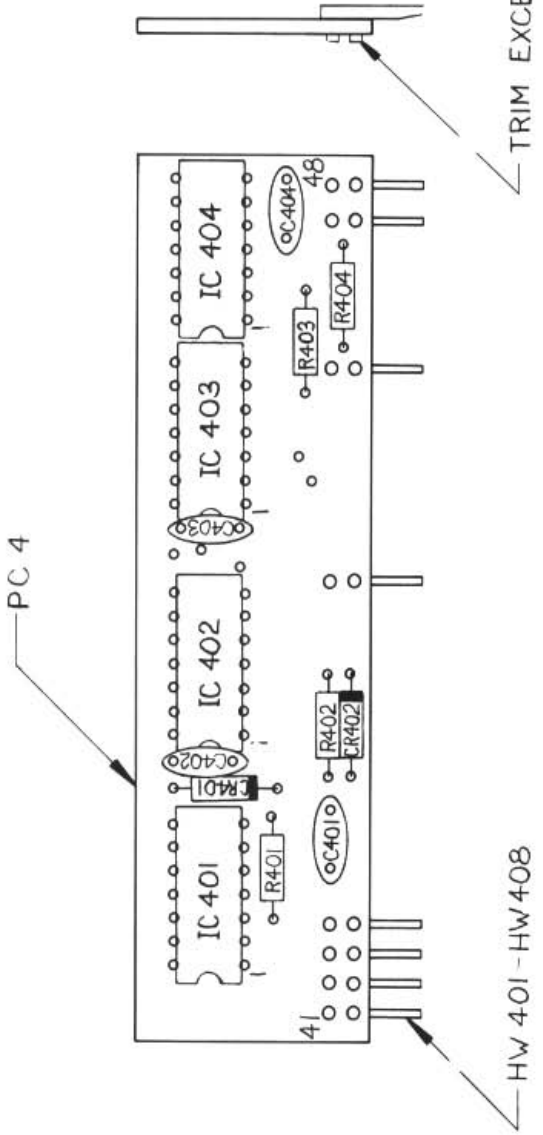

TRIM EXCESS, TYP.

HW 401 - HW 408

2. THIS BOARD HAS PLATED-THRU HOLES & NEED ONLY BE SOLDERED ON REAR SIDE.  
1. ALL LEADS AND TERMINALS MUST BE SOLDERED TO PADS ON REAR SIDE.

NOTES: UNLESS OTHERWISE SPECIFIED

ITEM NO.	PART NUMBER	PART NAME	MANUFACTURER	REFERENCE DESIGNATION
-1	5-575	P.C. BOARD ASSEMBLY	MOORE INDUSTRIES INC.	
NO. REQ'D	LIST OF MATERIALS			
	DRAWN	T. HART		
	CHECK	R. Kelley 11/21/78		
	PROJ. ENGR.			
	CUSTR.			
VOL. UNLESS NOTED				
X ± .1				
XX ± .03				
.XX ± .010				
ANGLES: ± 30				
FINISH				
NEXT ASSEMBLY				
BASE NO.				
189-552-0C				
SCALE 2/1				
DO NOT SCALE DRAWING				
JOB NO. 189				
189-553-00A				

P.C. BOARD ASSEMBLY  
PLUG-IN, DIGITAL  
**SHM** PC 4  
SAMPLE MODE (STD.)



189-553-00A

REV	DESCRIPTION	DATE	BY	APPROV
B	ECO 4207	7/26/64		

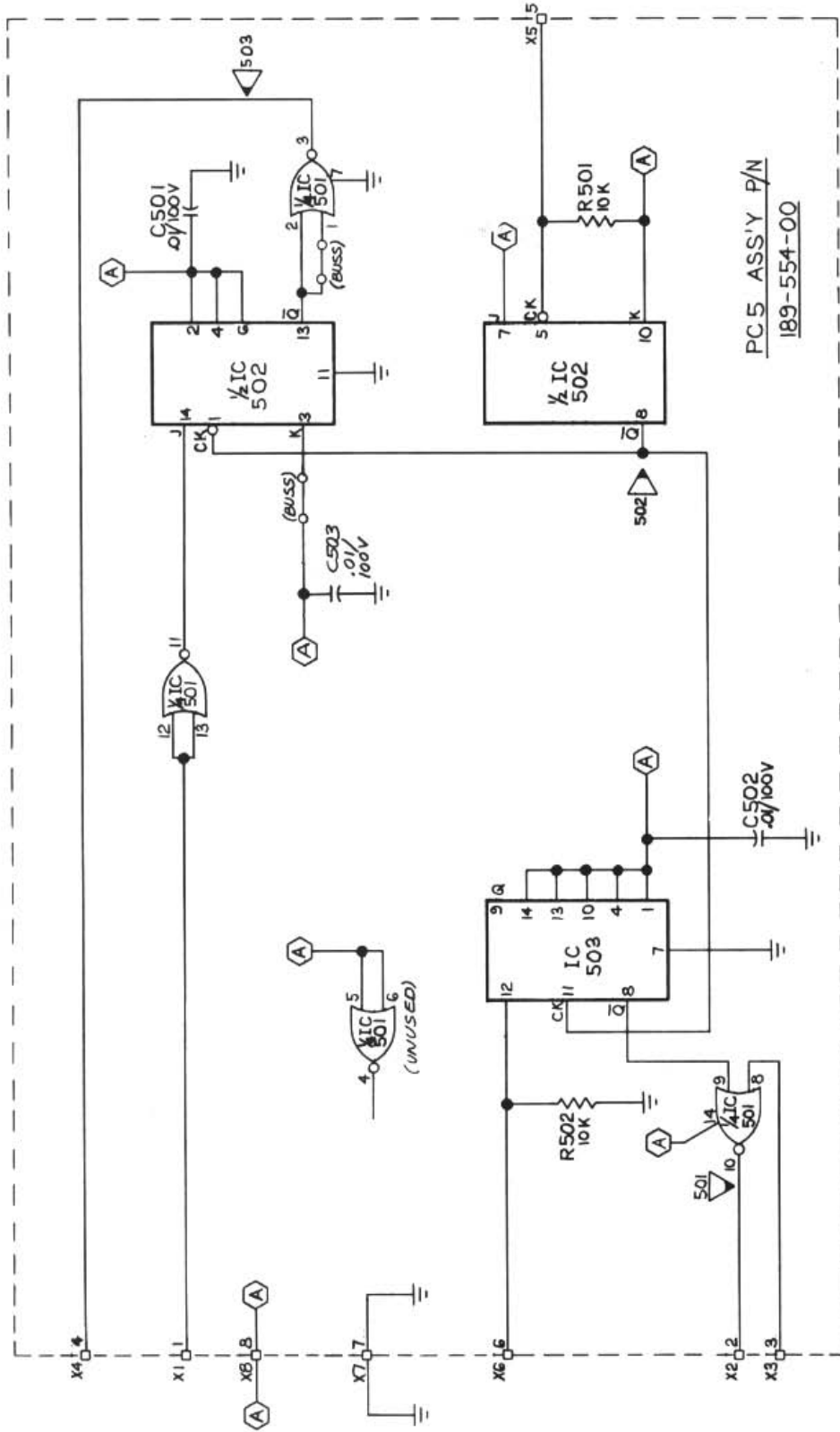

PC.5 ASS'Y P/N  
189-554-00

- 6. TEST POINT; FILLED END IS POINTER; SEE SECTION 5 OF MANUAL, "MAINTENANCE".
  - 5. CIRCUIT COMMON (GROUND).
  - 4. ELECTRICAL COMMONS, (SAME LETTERS); LETTERS DO NOT APPEAR ON PC BOARD OR ASSY DRAWING.
  - 3. □ PC/PC5 INTERCONNECT PIN.
  - 2. IC 501 IS M.I.I. PN 800-807-32; IC 502 IS 800-804-32; IC 503 IS 800-806-32; DIODES ARE 800-4148-11; RESISTORS ARE 1/4W CARB. COMP, ±10%.
  - 1. RESISTANCE IN OHMS; CAPACITANCE IN MICROFARADS.
- NOTES: UNLESS OTHERWISE SPECIFIED

ITEM	PART NUMBER	PART NAME	MANUFACTURER	REFERENCE DESIGNATION
1	800-807-32	IC 501	MOORE INDUSTRIES INC.	
2	800-804-32	IC 502	MOORE INDUSTRIES INC.	
3	800-806-32	IC 503	MOORE INDUSTRIES INC.	
4	800-4148-11	DIODES	MOORE INDUSTRIES INC.	
5	800-554-00	PC.5 ASS'Y	MOORE INDUSTRIES INC.	
LIST OF MATERIALS T. HART 9575 R. K. B. 9476 CHECKED BY: R. K. B. DRAWN BY: R. K. B. PART NUMBER: 189-554-00 PART NAME: PC.5 ASS'Y MANUFACTURER: MOORE INDUSTRIES INC. SCALE: 1:1 DATE: 7/26/64 JOB NO: 189				SCHEMATIC PLUG-IN, DIGITAL <b>SHM</b> "TR" OPTION DO NOT SCALE DRAWING MOORE INDUSTRIES INC. VAN NUYS - CALIF. 189-454-00B

REV.	DESCRIPTION	DATE	BY	APPRV
B	ECO 4207	12/3/87	CA	

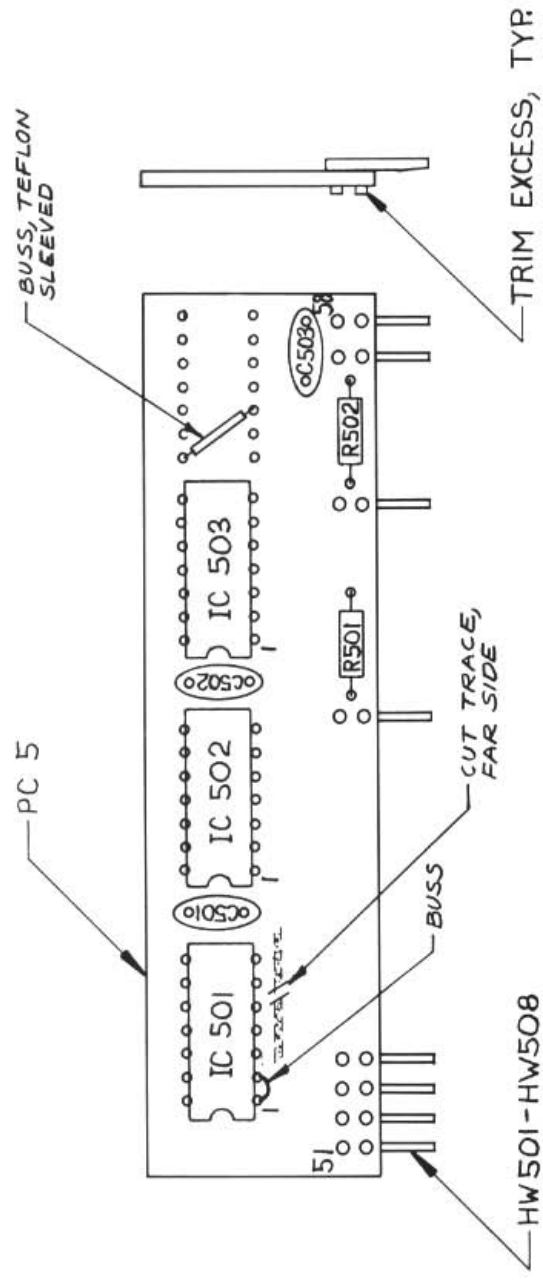

**WARNING**  
DO NOT TOUCH LEADS  
OF INTEGRATED CIRCUITS  
WITH FINGERS.

2. THIS BOARD HAS PLATED-THRU HOLES & NEED ONLY BE SOLDERED ON REAR SIDE.
1. ALL LEADS AND TERMINALS MUST BE SOLDERED TO PADS ON REAR SIDE.

NOTES: UNLESS OTHERWISE SPECIFIED

ITEM NO.	PART NUMBER	PART NAME	MANUFACTURER	REFERENCE DESIGNATION
-1				
NO. REQ'D	LIST OF MATERIALS			
189-552-0		T. HART	5-5-75	P.C. BOARD ASSEMBLY
		9/3/76		PLUG-IN, DIGITAL
		R. Kelly		SHM PC-5
				"-TR" OPTION
				DO NOT SCALE DRAWING
				SCALE 2/1
				JOB NO. 169
				189-554-00B
				MOORE INDUSTRIES INC. VAN NUYS • CALIF.

REV	DESCRIPTION	DATE	BY	APPROV
A	INITIAL RELEASE	7/1/82	T.H.	R.Y.

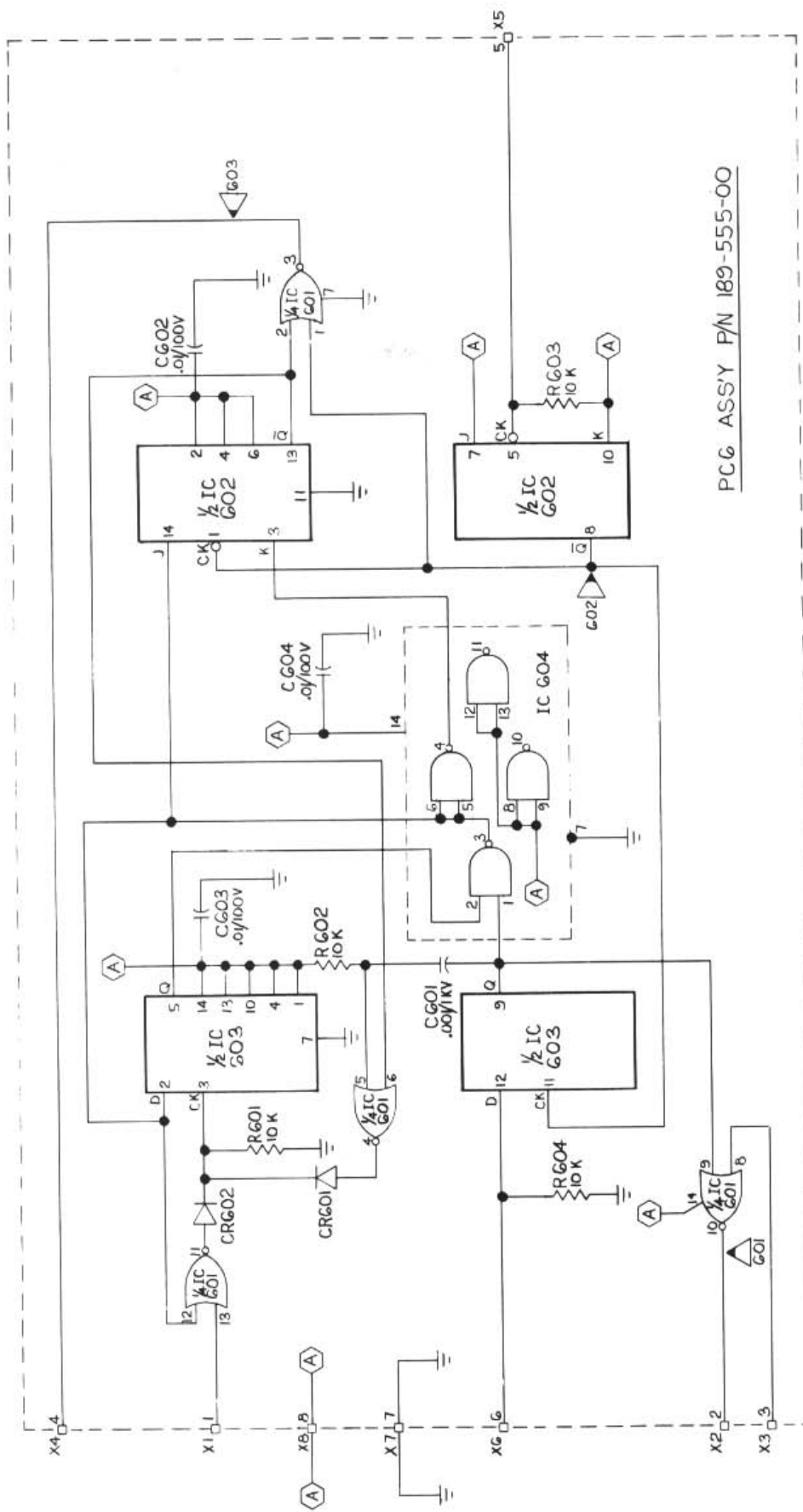

PCG ASS'Y P/N 189-555-00

- 6. TEST POINT: FILLED END IS POINTER; SEE SECTION 5 OF MANUAL, "MAINTENANCE".
- 7. CIRCUT COMMON (GROUND).
- 8. ELECTRICAL COMMONS, (SAME LETTERS); LETTERS DO NOT APPEAR ON P.C. BOARD OR ASSY DRAWING.
- 9. □ PCI/PCG INTERCONNECT PIN.
- 2. IC G01 IS M.I.I. P/N 800-807-32; IC G02 IS 800-804-32; IC G03 IS 800-806-32; IC G04 IS 800-808-32; DIODES ARE 800-414B-11; RESISTORS ARE 1/4 W, CARB. COMP, ±10%.
- 1. RESISTANCE IN OHMS; CAPACITANCE IN MICROFARADS.

NOTES: UNLESS OTHERWISE SPECIFIED

-1 NO. 189-555-00		ITEM	PART NUMBER	PART NAME	REFERENCE DESIGNATION
LIST OF MATERIALS					
DRWN	T. HART	3-5-75			
CHECK	R. Kelly				
PROJ. NO.	800-800				
PROJ. NAME	ANGLES - # 28				
FINISH					
ATTORNEY SIGN					
DATE					
CURT					
SCALE					
MOORE INDUSTRIES INC. VAN NUYS - CALIF.		SCHEMATIC PLUG-IN, DIGITAL <b>SHM</b> PC G "-PP" OPTION DO NOT SCALE DRAWING			
		189-455-00A			



REV.	DESCRIPTION	DATE	BY	APPRV
A	INITIAL RELEASE	7/1/76	T.H.	prob

# WARNING

DO NOT TOUCH LEADS  
OF INTEGRATED CIRCUITS  
WITH FINGERS.

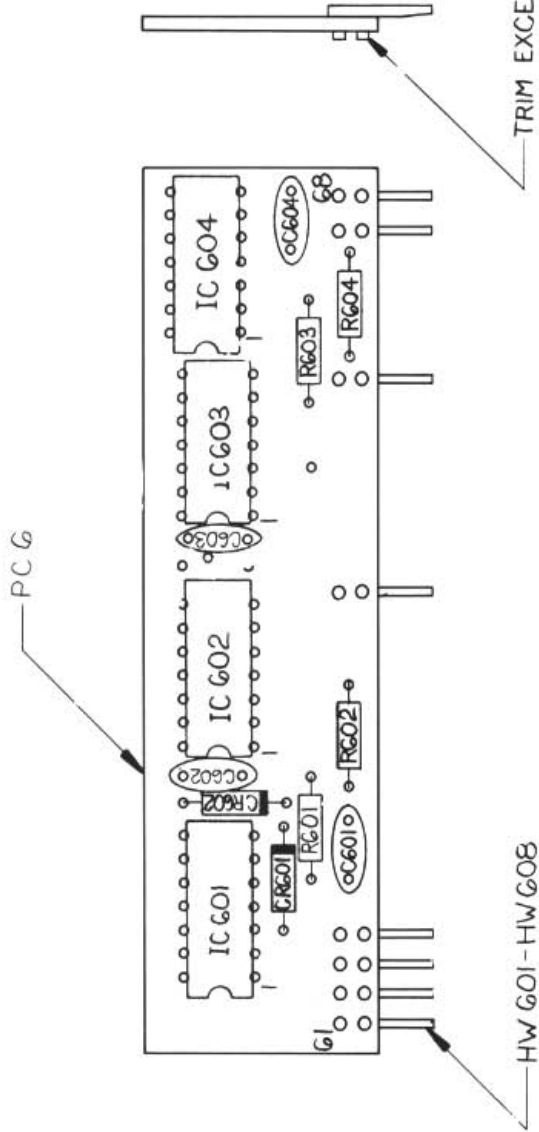

2. THIS BOARD HAS PLATED-THRU HOLES & NEED ONLY BE SOLDERED ON REAR SIDE.
1. ALL LEADS AND TERMINALS MUST BE SOLDERED TO PADS ON REAR SIDE.

NOTES: UNLESS OTHERWISE SPECIFIED

ITEM NO.	PART NUMBER	PART NAME	MANUFACTURER	REFERENCE DESIGNATION
-1	5-6-75	P.C. BOARD ASSEMBLY		
NO. REQ'D		LIST OF MATERIALS		
		DRAWN T. HART		
		CHECK R. Kelly 7/15/76		
		PROJ. ENGR.		
		CUSTR.		
		FINISH		
		PLATED THRU HOLES UNLESS NOTED		
		.X ±.1		
		.XX ±.03		
		.XXX ±.010		
		ANGLES: ±30		
		DO NOT SCALE DRAWING		
		SCALE 2/1	JOB NO. 189	
				189-555-00A



MOORE INDUSTRIES INC.  
VAN NUYS • CALIF.

189-555-00A

## RETURN PROCEDURES

### To return equipment to Moore Industries for repair, follow these four steps:

1. Call Moore Industries and request a Returned Material Authorization (RMA) number.

#### Warranty Repair –

If you are unsure if your unit is still under warranty, we can use the unit's serial number to verify the warranty status for you over the phone. Be sure to include the RMA number on all documentation.

#### Non-Warranty Repair –

If your unit is out of warranty, be prepared to give us a Purchase Order number when you call. In most cases, we will be able to quote you the repair costs at that time. The repair price you are quoted will be a "Not To Exceed" price, which means that the actual repair costs may be less than the quote. Be sure to include the RMA number on all documentation.

2. Provide us with the following documentation:
  - a) A note listing the symptoms that indicate the unit needs repair
  - b) Complete shipping information for return of the equipment after repair
  - c) The name and phone number of the person to contact if questions arise at the factory
3. Use sufficient packing material and carefully pack the equipment in a sturdy shipping container.
4. Ship the equipment to the Moore Industries location nearest you.

The returned equipment will be inspected and tested at the factory. A Moore Industries representative will contact the person designated on your documentation if more information is needed. The repaired equipment, or its replacement, will be returned to you in accordance with the shipping instructions furnished in your documentation.

#### WARRANTY DISCLAIMER

THE COMPANY MAKES NO EXPRESS, IMPLIED OR STATUTORY WARRANTIES (INCLUDING ANY WARRANTY OF MERCHANTABILITY OR OF FITNESS FOR A PARTICULAR PURPOSE) WITH RESPECT TO ANY GOODS OR SERVICES SOLD BY THE COMPANY. THE COMPANY DISCLAIMS ALL WARRANTIES ARISING FROM ANY COURSE OF DEALING OR TRADE USAGE, AND ANY BUYER OF GOODS OR SERVICES FROM THE COMPANY ACKNOWLEDGES THAT THERE ARE NO WARRANTIES IMPLIED BY CUSTOM OR USAGE IN THE TRADE OF THE BUYER AND OF THE COMPANY, AND THAT ANY PRIOR DEALINGS OF THE BUYER WITH THE COMPANY DO NOT IMPLY THAT THE COMPANY WARRANTS THE GOODS OR SERVICES IN ANY WAY.

ANY BUYER OF GOODS OR SERVICES FROM THE COMPANY AGREES WITH THE COMPANY THAT THE SOLE AND EXCLUSIVE REMEDIES FOR BREACH OF ANY WARRANTY CONCERNING THE GOODS OR SERVICES SHALL BE FOR THE COMPANY, AT ITS OPTION, TO REPAIR OR REPLACE THE GOODS OR SERVICES OR REFUND THE PURCHASE PRICE. THE COMPANY SHALL IN NO EVENT BE LIABLE FOR ANY CONSEQUENTIAL OR INCIDENTAL DAMAGES EVEN IF THE COMPANY FAILS IN ANY ATTEMPT TO REMEDY DEFECTS IN THE GOODS OR SERVICES, BUT IN SUCH CASE THE BUYER SHALL BE ENTITLED TO NO MORE THAN A REFUND OF ALL MONIES PAID TO THE COMPANY BY THE BUYER FOR PURCHASE OF THE GOODS OR SERVICES.

ANY CAUSE OF ACTION FOR BREACH OF ANY WARRANTY BY THE COMPANY SHALL BE BARRED UNLESS THE COMPANY RECEIVES FROM THE BUYER A WRITTEN NOTICE OF THE ALLEGED DEFECT OR BREACH WITHIN TEN DAYS FROM THE EARLIEST DATE ON WHICH THE BUYER COULD REASONABLY HAVE DISCOVERED THE ALLEGED DEFECT OR BREACH, AND NO ACTION FOR THE BREACH OF ANY WARRANTY SHALL BE COMMENCED BY THE BUYER ANY LATER THAN TWELVE MONTHS FROM THE EARLIEST DATE ON WHICH THE BUYER COULD REASONABLY HAVE DISCOVERED THE ALLEGED DEFECT OR BREACH.

#### RETURN POLICY

For a period of thirty-six (36) months from the date of shipment, and under normal conditions of use and service, Moore Industries ("The Company") will at its option replace, repair or refund the purchase price for any of its manufactured products found, upon return to the Company (transportation charges prepaid and otherwise in accordance with the return procedures established by The Company), to be defective in material or workmanship. This policy extends to the original Buyer only and not to Buyer's customers or the users of Buyer's products, unless Buyer is an engineering contractor in which case the policy shall extend to Buyer's immediate customer only. This policy shall not apply if the product has been subject to alteration, misuse, accident, neglect or improper application, installation, or operation. THE COMPANY SHALL IN NO EVENT BE LIABLE FOR ANY INCIDENTAL OR CONSEQUENTIAL DAMAGES.



**WORLDWIDE • www.miinet.com**

United States • info@miinet.com Tel: (818) 894-7111 • FAX: (818) 891-2816	Belgium • info@mooreind.be Tel: 03/448.10.18 • FAX: 03/440.17.97	China • sales@mooreind.sh.cn Tel: 86-21-62491499 • FAX: 86-21-62490635
Australia • sales@mooreind.com.au Tel: (02) 8536-7200 • FAX: (02) 9525-7296	The Netherlands • sales@mooreind.nl Tel: (0)344-617971 • FAX: (0)344-615920	United Kingdom • sales@mooreind.com Tel: 01293 514488 • FAX: 01293 536852